

# SECTION 0

# 2004 Police Interceptor Modifier Guide

## Contents

Introduction.....0-1

## Introduction

Ford Motor Company has assembled this Police Interceptor Modifier Guide to assist vehicle modifiers in producing safe and quality products. Ford believes that safety and quality come first, and to achieve customer satisfaction, we want to assist modifiers in achieving the highest standards of safety and quality in their products.

This book is divided into topics pertinent to modifiers of police vehicles. Reference will be made to the current Ford Crown Victoria Workshop Manual for appropriate service procedures, torque specifications, component separation clearances, and other standard information which is common with the unmodified vehicle. Specifications provided which are unique to the guide will be so designated.

This modifier guide is not a “how-to” book; it should be used as a checklist to help ensure that certain important steps in the modification process have been considered. While Ford is providing this information to assist modifiers, it does not warrant the products, methods, materials, or the workmanship of the modifier. Nor does it warrant against failures that result from the modification of a vehicle.

Following the guidelines contained in this guide does not assure individual modifiers that the products they modify comply with U.S. Federal or Canadian Motor Vehicle Safety Standards in effect at the time of the modification. The guidelines set forth are based on engineering analyses of typical police vehicles. If followed, the modifier’s efforts in certifying vehicles to applicable standards should be aided. Compliance testing that may be required for certification of specific vehicle configurations or constructions is, however, the sole responsibility of the individual modifier.

The only Crown Victoria models suitable for use in police service are the pursuit-related Police Interceptor (body code P71) and the Commercial Heavy Duty Use Long Wheel Base Crown Victoria (body code P70) with the optional police package.

DuPont™ and KEVLAR® are trademarks or registered trademarks of DuPont or its affiliates.

# SECTION 1

## 2004 Police Interceptor Modifier Guide

### Contents

Section 1: General Information .....	1-1
Important Safety Notice .....	1-1
Police Vehicle Definition .....	1-3
Identification Codes .....	1-8
Vehicle Certification (VC) Label .....	1-11
Good Practices .....	1-15
New Vehicle Storage .....	1-16
Bumper Heights .....	1-17

## Section 1: General Information

### Important Safety Notice

Note: The descriptions and specifications contained in this guide were in effect at the time this manual was approved for printing. Ford Motor Company reserves the right to discontinue models at any time, or change specifications or design without notice and without incurring obligation.

Appropriate repair methods and procedures are essential for the safe, reliable operation of all motor vehicles as well as the personal safety of the individual doing the work. This manual provides general directions and guidelines for performing modifications to the Police Interceptor. Following them will help assure reliability.

There are numerous variations in procedures, techniques, tools, and parts for modifying vehicles, as well as in the skill of the individual doing the work. This manual cannot possibly anticipate all such variations and provide advice or cautions as to each. Accordingly, anyone who departs from the instructions provided in this manual must first establish that he compromises neither his personal safety nor the vehicle integrity by his choice of methods, tools or parts.

## Section 1: General Information

### Notes, Cautions, and Warnings

As you read through this guide, you will come across NOTES, CAUTIONS and WARNINGS. Each one is there for a specific purpose. NOTES give you added information that will help you to complete a particular procedure. CAUTIONS are given to prevent you from making an error that could damage the vehicle. WARNINGS remind you to be especially careful in those areas where carelessness can cause you personal injury. The following list contains some general warnings that you should follow when you work on a vehicle.



#### **WARNING:**

- **ALWAYS WEAR SAFETY GLASSES FOR EYE PROTECTION.**
- **USE SAFETY STANDS WHENEVER A PROCEDURE REQUIRES YOU TO BE UNDER THE VEHICLE.**
- **MAKE SURE THAT THE IGNITION SWITCH IS ALWAYS IN THE OFF POSITION, UNLESS OTHERWISE REQUIRED BY THE PROCEDURE.**
- **SET THE PARKING BRAKE WHEN WORKING ON THE VEHICLE. THE GEAR SELECTOR SHOULD BE SET IN PARK UNLESS INSTRUCTED OTHERWISE FOR A SPECIFIC OPERATION. PLACE WOOD BLOCKS (4 INCH X 4 INCH OR LARGER) AGAINST THE FRONT AND REAR SURFACES OF THE TIRES TO HELP PREVENT THE VEHICLE FROM MOVING.**
- **OPERATE THE ENGINE ONLY IN A WELL-VENTILATED AREA TO AVOID THE DANGER OF CARBON MONOXIDE POISONING.**
- **KEEP YOURSELF AND YOUR CLOTHING AWAY FROM MOVING PARTS WHEN THE ENGINE IS RUNNING, ESPECIALLY THE DRIVE BELTS.**
- **TO REDUCE THE RISK OF SERIOUS BURNS, AVOID CONTACT WITH HOT METAL PARTS SUCH AS THE RADIATOR, EXHAUST MANIFOLD, TAILPIPE, CATALYTIC CONVERTER AND MUFFLER.**
- **DO NOT SMOKE WHILE WORKING ON A VEHICLE.**
- **TO REDUCE THE RISK OF INJURY, ALWAYS REMOVE RINGS, WATCHES, LOOSE HANGING JEWELRY AND LOOSE CLOTHING BEFORE BEGINNING TO WORK ON A VEHICLE.**
- **WHEN IT IS NECESSARY TO WORK UNDER THE HOOD, KEEP HANDS AND OTHER OBJECTS CLEAR OF THE RADIATOR FAN BLADES! FAILURE TO FOLLOW THESE INSTRUCTIONS MAY RESULT IN PERSONAL INJURY.**

### **Making Safety Devices and Elements Inoperative**

The vehicle contains many safety features required by Federal or Canadian Motor Vehicle Safety Standards. These features, which include the key-in-ignition chime and brake lights, should never be disabled or modified.

## Section 1: General Information

CFR 49 Section 30122 states that “A manufacturer, distributor, dealer, or motor vehicle repair business may not knowingly make inoperative any part of a device or element of design installed on or in a motor vehicle or motor vehicle equipment in compliance with an applicable motor vehicle safety standard prescribed under this chapter unless the manufacturer, distributor, dealer, or repair business reasonably believes the vehicle or equipment will not be used (except for testing or a similar purpose during maintenance or repair) when the device or element is inoperative.”

### Police Vehicle Definition

#### Standard Equipment — Exterior

Item	Description
Bumpers	Concealed with one piece full wrap cover, body color
Decklid	Low lift-over design
Glass	Solar tinted, full with ceramic shade band behind rear view mirror
Grille	Black/center Ford oval design
Hub caps	Snap on over lug nuts
Lights	Low profile dual aero halogen headlamps with Crystalline krypton long life bulbs in the side/turning markers
Mirrors	Black fold-away dual remote control power
Moldings	Black rocker panel Black windshield and backlight Bright surround on side windows Color keyed bodyside (except special order (VSO) colors which have narrow black moldings)
Paint	Clear coat Anti-chip paint primer Body color B-pillars
Urethane Protection	Lower bodyside

#### Standard Equipment — Interior

Item	Description
Cigarette Lighter	In instrument panel center stack
Cup Holders	Dual ashtray mounted
Defroster Grille	With integral vertical ribs
Door Trim Panels	Front with armrests; ashtrays deleted from rear door trim panels
Flooring	Heavy duty rubber
Fuse Panel	Easy access, labeled
Gauge Cluster	Four analog gauges (volt, oil pressure, water temperature and fuel)
Glove Box	Illuminated, large bin, lockable with dampened glove box door, zippered owner's pouch with embossed car-line logo
Headliner	Removable with high intensity dome lamp (includes 5" round map light mounted behind rear view mirror)

(Continued)

## Section 1: General Information

### Standard Equipment — Interior

Item	Description
Head Restraints	2-Way
Instrument Panel	With side window de-misters
Lamps	Dome, luggage and engine compartment
Luggage Compartment Trim	Full carpet
Map Pockets	Integral front door
Mirror	Day/night inside rear view
Radio Speakers	Front door mounted, located above armrests and in the package tray)
Personal Safety System W/Dual Stage Air Bags	Driver and right front passenger (includes safety belt pretensioners, dual stage airbags, seat position and weight sensors)
Safety Belts	3-Point active for front and rear outboard occupants (safety belt pretensioners on front seat shoulder belts)
Scuff Plates	Color keyed, front and rear doors
Seats	Cloth bucket/vinyl rear seats with power lumbar driver seat and manual recline; storage pockets on driver/passenger seats; rear seat excludes center armrest
Steering Wheel	Color keyed with center horn activation
Sun Visors	Cloth covered with retention clips
Tilt Steering Wheel	Mounted stalk controls for washer/wipers, hi/low headlamp beam, turn signal, and flash-to-pass
Trip Odometer	—
Trunk	Deep well, carpeted

### Standard Equipment — Functional

Item	Description
Air Conditioning	Manual with positive shutoff registers Wide-open-throttle shut off
Generator	200-Amp maximum output, 131-amps at idle
Antenna, Radio	Hidden in rear window defroster
Battery	Maintenance free 78-AH, 750 CCA
Battery Saver	Turns off lights after 30 minutes
Body-On-Frame Construction	Hydroformed steel frame
Brake Shift Interlock Protection	Brake pedal must be depressed to engage transmission
Child Safety Latches On Rear Doors	—
Full Size Spare Tire And Wheel	—
Coolant Recovery System	—
Decklid Release	On center instrument panel, battery operated
Defroster, Rear Window	—
Disc Brakes	Power 4-wheel Anti-Lock Braking System (ABS)
Drive Shaft	Aluminum

(Continued)

## Section 1: General Information

### Standard Equipment — Functional

Item	Description
Engine	4.6L overhead cam, SEFI V8
Engine Oil Cooler	—
Exhaust System	Stainless steel, dual
Fail Safe Cooling	—
Fan	Multi speed electrodrive, PCM controlled
Front Stabilizer Bar	—
Front Suspension	Short/long arm
Fuel Filler Cap	Tethered
Fuel Tank	19 gallon
Glass	Solar tinted, full
Headlamps	Halogen with "on" reminder chime
Heat Ducts	Front and rear floor mounted
Frame, Steering Gear/Rack And Pinion, Body Mounts And Suspension	Heavy Duty
Hood Assists	Gas cylinder, monotube
Horn	Dual note
Ignition System	Electronic distributorless
Jack	Scissors
Light Bar Connector	50-Amp battery circuit at base of right hand B-pillar underneath trim (N/A with 65A, 68P or 65W)
Parking Brake	Single stroke, manual release
Parking Brake Release	Manual
Passenger Capacity	Five
Plastic Head Ignition Key	Primary only
Power Steering	3 turn lock-to-lock with variable assist
Power Steering Oil Cooler	Integral with transmission oil cooler
Rear Stabilizer Bar	—
Rear Suspension	Watt's linkage
Shock Absorbers	Nitrogen pressurized, monotube
Speedometer	140 mph certified calibration in 2 mph increments
Tires	P225/60R16 97V — All-season BSW Goodyear Eagle RSA Plus
Transmission	Electronically controlled automatic overdrive (with OD lockout) with final drive ratio of 3.27:1
Transmission Oil Cooler	Shared with power steering cooler
Upper Ball Joints	Low friction, non-greaseable
Voltage Regulator	Electronic, integral to generator
Wheel Rims	Heavy duty steel (16 x 7)
Windows	Power with express-down driver window
Windshield Washers	Dual jet
Windshield Wipers	Interval



## Section 1: General Information

### Miscellaneous Options (See sales brochure for complete list of available options)

Item	Description
Power Distribution Box, Front (66F)	10 fuses, 4 ground terminals and connections for feeds and signals <ul style="list-style-type: none"> <li>• Vehicle speed output</li> <li>• Start — Indicates when vehicle is being started               <ul style="list-style-type: none"> <li>• Battery saver — removes power 30 minutes after vehicle has been turned OFF if no doors have been opened</li> </ul> </li> <li>• Hazard ON</li> <li>• Hazard OFF</li> </ul>
Radio Suppression Package (53M)	Hood to body (LH/RH) Engine to dash panel Engine to frame Tail pipe to frame (LH/RH) Decklid to body (LH/RH) Body to frame rear (LH/RH)
Comfort And Convenience Group (41A)	Power driver seat Speed control AM/FM stereo with cassette
Street Appearance Package (60B)	Color keyed retail bodyside moldings Rear applique with color keyed panels "Crown Victoria" badge Chrome grille Chrome fascia inserts Chrome door handle bezel Chrome taillamp applique Wheel covers, full
Wiring Prep Package (476)	Pre-wire for package tray warning lamps and inner decklid lamp
Spot Lamp Wiring Prep (51B/51Z)	Contains wiring, brackets and body preparation for installation of spot lamp kit purchased from manufacturer <ul style="list-style-type: none"> <li>Access hole in A-pillar</li> <li>Mounting bracket in place</li> <li>A-pillar moldings trimmed</li> </ul> Wiring & fuse located in standard fuse panel Door edge reworked and trimmed (Not available with 51A/51Y Spot Lamp)
Driver Side Spot (51A) Assembly and Dual Spot Assembly (51Y)	Includes functioning driver side spot lamp or driver and passenger side spot lamps

### Police Prep Package Options

Description	65A	68P	65W	65N
2 front strobe bulbs and 2 rear strobe bulbs	X	X	X	X
Alternating headlight flasher	X	X	X	X

(Continued)

## Section 1: General Information

### Police Prep Package Options

Description	65A	68P	65W	65N
Wiring harness including the following items: <ul style="list-style-type: none"> <li>• Six (6) strobe cables, shielded and grounded</li> <li>• Distribution centers located in the glove box and trunk. 50 amp each. Fused in engine compartment. Each distribution center has 5 ground wires and can hold 6 fuses (3 battery and 3 ignition powered).</li> <li>• 5 glove box battery ground wires.</li> <li>• 50 amp battery circuit and ground available at passenger A-pillar lower trim panel in trunk for radio communications.</li> <li>• Siren/speaker wiring pre-run to front of vehicle available at console or trunk.</li> <li>• Horn/siren relay circuit available at console or trunk.</li> <li>• 4 extra circuits pre-run from the engine compartment to the console.</li> <li>• 4 extra circuits pre-run from the console to the trunk.</li> </ul>	X	X	X	X
Console mounting platform		X	X	X
Center wiring conduit		X	X	
Hidden manual door lock plunger located in door frame		X	X	
Trunk air circulation fan		X	X	
Permanent rubber tie down strap		X	X	
Dual trunk storage boxes		X	X	
Rear trunk communications service tray		X	X	
Strobe power supply			X	X
Two (2) flashing rear deck high intensity LED lights with matching interior color housings			X	X
Visibility switch panel including 4 position slide switch and 4 rocker switches			X	X
Lighting relay center for use with visibility switch panel — controls up to 8 light bar functions			X	X

65A — Police Prep Package Base, 68P — Police Prep Package Complete, 65W — Visibility Package, 65N — Visibility Base (available for vehicles built after 12/2003)

Note: 68P includes everything in 65A. 65W requires that 68P be ordered.  
 65N requires that 65A be ordered.

## Section 1: General Information

### Identification Codes

#### Vehicle Identification Number (VIN) Location

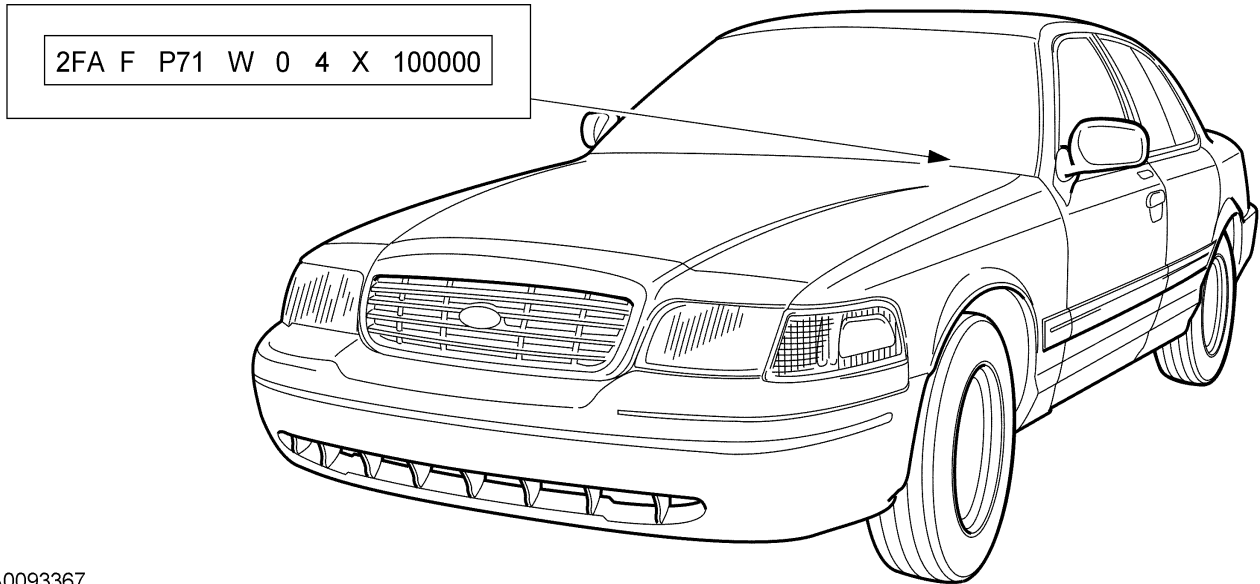

A0093367

#### Vehicle Identification Number (VIN) Positions

The Vehicle Identification Number (VIN) is a seventeen-digit combination of letters and numbers. The VIN is stamped on a metal tab riveted to the instrument panel, top upper left of the dash. The VIN is also found on the Vehicle Certification (VC) label.

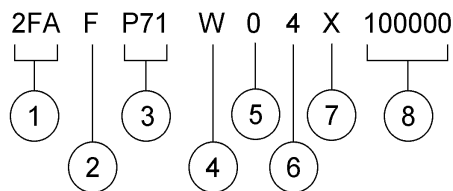

A0093368

Position	Description
1	World manufacturer identifier (WMI)
2	Restraint type code

(Continued)

## Section 1: General Information

Position	Description
3	Vehicle line and series code
4	Engine code
5	VIN check digit
6	Model year code
7	Assembly plant code
8	Production sequence number

### 1. World Manufacturer Identifier (WMI)

The first three vehicle identification number (VIN) positions are the world manufacturer identifier (WMI) code.

- 2FA — Ford, Canada, passenger car

### 2. Restraint Type Code

The fourth VIN position is the vehicle restraint system type code.

- F — Active safety belts — all positions, driver and front passenger air bags
- H — Active safety belts — all positions, driver and front passenger air bags and driver and front passenger side impact air bags

### 3. Vehicle Line and Series Code

Positions 5 through 7 indicate vehicle line, series and body type.

- P70 — Crown Victoria (Long wheel base)
- P71 — Crown Victoria (Police)

### 4. Engine Code

The eighth VIN position is the engine displacement and number of cylinders code.

- W — 4.6L EFI (SOHC), eight cylinder, gasoline
- 9 — 4.6L EFI (SOHC), eight cylinder, compressed natural gas (CNG)

### 5. Check Digit Code

The ninth VIN position is the check digit code (0-9).

## Section 1: General Information

### 6. Model Year Code

The tenth VIN position is the model year code.

- 4 — 2004

### 7. Assembly Plant Code

The eleventh VIN position is the assembly plant code.

- X — St. Thomas, Talbotville, Ontario (Canada)

### 8. Production Sequence Code

The last six VIN positions are the production sequence number. These six digits also are used as the vehicle serial and warranty number.

- Ford — starts at 100000

# Section 1: General Information

## Vehicle Certification (VC) Label

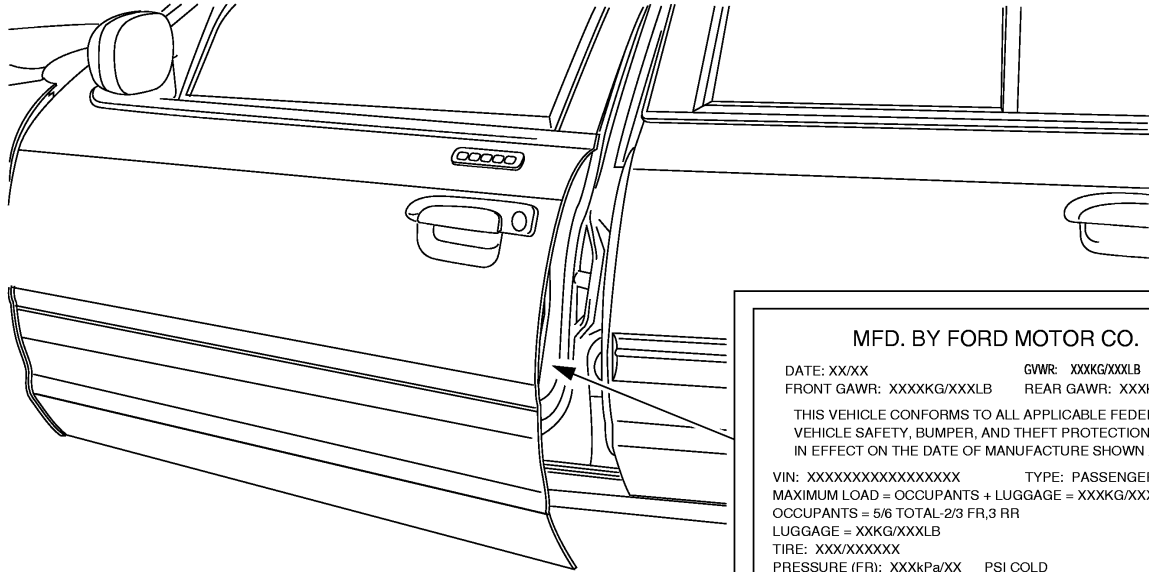

MFD. BY FORD MOTOR CO.

DATE: XX/XX                      GVWR: XXXKG/XXXLB  
FRONT GAWR: XXXKG/XXXLB    REAR GAWR: XXXKG/XXXLB

THIS VEHICLE CONFORMS TO ALL APPLICABLE FEDERAL MOTOR  
VEHICLE SAFETY, BUMPER, AND THEFT PROTECTION STANDARDS  
IN EFFECT ON THE DATE OF MANUFACTURE SHOWN ABOVE.

VIN: XXXXXXXXXXXXXXXX                      TYPE: PASSENGER  
MAXIMUM LOAD = OCCUPANTS + LUGGAGE = XXXKG/XXXLB  
OCCUPANTS = 5/6 TOTAL-2/3 FR,3 RR  
LUGGAGE = XXXKG/XXXLB  
TIRE: XXX/XXXXX  
PRESSURE (FR): XXXkPa/XX    PSI COLD  
PRESSURE (RR): XXXkPa/XX    PSI COLD



XXXXXXXXXXXXXXXXXXXX

TRAILER TOWING - SEE OWNER GUIDE

EXT PNT:	XX					RC:	72	DSO:	XXXX
BRK	INT TR	TP/PS	R	AXLE	TR	SPR	XXXX	XXXX	XXXX
X	XX	XX	X	XX	X	XXX	XXXX	XXXX	XXXX

A0075059

The upper portion of the vehicle certification (VC) label contains the manufacturer name, the month and year of manufacture, the certification statement and the VIN. It also includes the gross vehicle weight rating (GVWR) and the gross axle weight rating (GAWR), as well as tire size and pressure ratings. The VC label is located on the left-hand front door edge.

# Section 1: General Information

## Vehicle Certification (VC) Label Code Positions

MFD. BY FORD MOTOR CO.

DATE: XX/XX GVWR: XXXKG/XXXLB  
FRONT GAWR: XXXXKG/XXXLB REAR GAWR: XXXKG/XXXLB

THIS VEHICLE CONFORMS TO ALL APPLICABLE FEDERAL MOTOR  
VEHICLE SAFETY, BUMPER, AND THEFT PROTECTION STANDARDS  
IN EFFECT ON THE DATE OF MANUFACTURE SHOWN ABOVE.

VIN: XXXXXXXXXXXXXXXX TYPE: PASSENGER  
MAXIMUM LOAD = OCCUPANTS + LUGGAGE = XXXKG/XXXLB  
OCCUPANTS = 5/6 TOTAL-2/3 FR,3 RR  
LUGGAGE = XXKG/XXXLB  
TIRE: XXX/XXXXXX  
PRESSURE (FR): XXXkPa/XX PSI COLD  
PRESSURE (RR): XXXkPa/XX PSI COLD



XXXXXXXXXXXXXXXXXXXX ← 11

TRAILER TOWING - SEE OWNER GUIDE

EXT PNT: XX | RC: 72 | DSO: | XXXXX

BRK | INT | TR | TP/PSI | R | AXLE | TR | SPR | XXXXX | XXXXX  
X | XX | XX | X XX | X | XXX | XXXXX | XXXXX

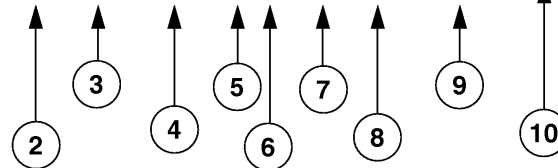

A0075394

Position	Description
1	Exterior paint color code
2	Brake type code
3	Interior trim code
4	Tape/paint stripe code
5	Radio type code
6	Axle ratio code
7	Transmission code
8	Spring code
9	Engine calibration information
10	Powertrain calibration information
11	Vehicle identification number (VIN)

## Section 1: General Information

### 1. Paint Code

The first set of numbers/letters listed indicate the vehicle primary body color code. The second set of letters/numbers listed (if applicable), indicate a two-tone or accent body color code.

- JP — Silver Birch (clear coat metallic)
- UA — Black (clear coat)
- WT — Vibrant White (clear coat)
- FS — Spruce Green (clear coat metallic)
- JL — Dark Toreador Red (clear coat metallic)
- TV — Midnight Gray
- AQ — Arizona Beige (clear coat metallic)
- LS — Light Ice Blue (clear coat metallic)
- C2 — Gold Ash Metallic
- DX — Dark Blue Pearl (clear coat)
- LK — Dark Blue (police/fleet)
- LM — Royal Blue (police/fleet)
- MM — Ultra Blue (police/fleet) (clear coat metallic)
- LN — Light Blue Metallic (police/fleet)
- TN — Silver Gray Metallic (police/fleet)
- YG — Medium Titanium (police/fleet) (clear coat metallic)
- BU — Medium Brown Metallic (police/fleet)
- TM — Light Gray (police/fleet)

### 2. Brake Code

The brake type codes are:

- Blank — Four-wheel disc brakes with anti-lock brake system (ABS)
- 3 — Electronic traction control system (includes ABS)
- H — Police package (four-wheel disc brakes with ABS and unique police friction material)
- C — Police package with electronic traction control system (includes ABS)



## Section 1: General Information

### 3. Interior Trim Code

The interior trim codes are listed below. The first letter/number is for the interior fabric. The second letter is for the interior color.

- P — Laura cloth (split bench), Crown Victoria (fleet/police) with anti-stab feature, front and rear
- R — G-Grain Vinyl (split bench), Crown Victoria (fleet/police), front and rear
- H — Stockton Cloth (front bucket seats), Crown Victoria (fleet/police), cloth rear
- I — Stockton Cloth (front bucket seats), Crown Victoria (fleet/police), vinyl rear

The interior trim colors are:

- C — Light Flint
- H — Medium Parchment
- W — Midnight Black

### 4. Tape and Paint Stripe Code

Tape and paint stripe codes are not available with the P71 police package.

### 5. Radio Code

The radio type codes are:

- F — AM/FM electronic stereo
- H — AM/FM electronic stereo with cassette
- Y — Radio delete

### 6. Axle Ratio Code

The axle ratios are:

- 1 — 2.73 conventional (non-limited slip)
- 4 — 2.73 conventional (non-limited slip)
- 5 — 3.55 conventional (limited slip)
- C — 3.27 limited slip
- F — 3.55 locker

## Section 1: General Information

### 7. Transmission Code

The transmission codes are:

- U — Four-speed automatic overdrive, (4R70W) Livonia
- H — Four-speed automatic overdrive, (4R70W) Sharonville

### 8. Spring Code

The first number/letter listed identifies the front spring codes. The second number/letter listed identifies the rear spring codes.

The front spring codes are:

- N — D9AC-5310-ANA (Police)

The rear spring codes are:

- H — F8AC-5560-HA (Police)

### 9. Engine Calibration Information

Engine calibration information is located on the VC label lower right corner between the spring code field and the powertrain calibration information. Engine calibration information is limited to a maximum of five characters per line (two lines maximum). Calibration information more than five characters long will wrap to the second line of this field.

### 10. Powertrain Calibration Information

Powertrain calibration information is printed in the lower right corner of the Vehicle Certification Label. Only the base calibration information is printed. Revision levels will not appear. Powertrain calibration information is limited to a maximum of five characters per line on the Vehicle Certification Label. Calibration identification consisting of more than five characters will wrap to the second line on the VC label.

### 11. Vehicle Identification Number (VIN)

The Vehicle Identification Number (VIN) is located just below the bar code.

### Good Practices

#### Process And Quality Assurance Systems

A formalized Process and Quality Assurance system may be helpful in consistently producing high quality products. An overview of some of the key items for such a system are outlined in this section.

## Section 1: General Information

### Quality Assurance

Completed Unit Sign-Off: All control items should be inspected with a written sign-off. All labels should be inspected and signed off, including verification that the information on the labels is correct. All appropriate systems should be checked for leaks. A road test should be performed to verify that all systems are operating correctly. All systems and functions that were provided by Ford should be checked to ensure that they function correctly after the build process.

The modifier's Process and Quality Assurance Systems should also assure that appropriate training is provided to the employees.

### Minimum And Maximum Screw Sizes

When installing aftermarket equipment, avoid using fasteners that are too long for the application or are in an area which might damage vehicle components, including wiring, brake lines, fuel tank and lines, powertrain components, exhaust system, and suspension. Details for mounting of equipment in the trunk, as well as appropriate fasteners, can be found in Section 5, Trunk Mounting Considerations.

### New Vehicle Storage

#### New Vehicle Storage — General

- Vehicles should be stored in a dry, ventilated place, and protected from sunlight, if possible.
- If vehicles are stored outside, maintenance against rust and damage, as described below, is recommended.



**CAUTION: Keep all rubber parts free from oil and solvents.**

#### New Vehicle Storage — Body

- Wash vehicle thoroughly to remove dirt, grease, oil, tar, or mud from exterior surfaces and underside of front fender.
- Periodically wash vehicles stored in exposed locations.
- Touch up exposed raw or primed metal to provide rust protection.
- Cover chrome and stainless steel parts with a thick coat of auto wax to prevent discoloration. Rewax as necessary when the vehicle is washed.
- Lubricate all hood, door hinges and latches with a light grade oil.
- Cover the interior soft trim to prevent fading.

## Section 1: General Information

### New Vehicle Storage — Engine

- Start the engine every 15 days. Run it at fast idle until it reaches normal operating temperature.
- With foot on brake pedal (and brake applied), shift the transmission into all gears while the engine is running.

### New Vehicle Storage — Fuel System

- Regularly move vehicles short distances to mix fuel anti-oxidation agents.

Note: During extended periods of vehicle storage (60 days or more) gasoline may deteriorate due to oxidation. This can damage rubber and other polymers in the fuel system and may clog small orifices. A commercially available gasoline fuel stabilizer (Sta-Bil or equivalent) should be added to gasoline-powered vehicles whenever actual or expected storage periods exceed 60 days. The manufacturer's instructions packaged with the product should be followed. The vehicle should then be operated at an idle speed to circulate the additive throughout the fuel system.

### New Vehicle Storage — Tires

Most high performance tires are made with nylon overlay.

As such, the following steps should be taken to avoid flat spotting when the vehicles are not used for a period of time.

- Store the vehicles with 44 PSI in the tires. If the cars are to be driven, the air pressure should be reduced to recommended operating pressure and then increased back up to 44 PSI when returned to storage.
- If the vehicle is stored for periods longer than 30 days, it should be moved several feet at least once during each 30-day period, so that a different portion of the tread contacts the ground.

### Bumper Heights

After vehicle modification, the front and rear bumper heights must be verified to comply with FMVSS/CMVSS Part 581 and Ford specifications. Prior to determining bumper heights, the modified vehicle must be at curb weight. (See Engineering Guidelines, General Information, Weight Distribution Section for definition of Curb Weight.) Bumper heights are determined as follows:

- Place the vehicle on a level surface.
- Place the transmission selector lever in the P (Park) position.
- Turn off the ignition and exit the vehicle
- Measure the vertical distance from the floor surface to the bottom of the front bumper structural beam (not the bumper fascia surface) at points 8.3 inches to the left and to the right of the center of the bumper beam.

## Section 1: General Information

- Measure the vertical distance from the floor surface to the bottom of the rear bumper structural beam (not the bumper fascia surface) at points 25.6 inches to the left and to the right of the center of the bumper beam.
- Record these measurements.

Note: A maximum of 0.5 inch side to side difference in bumper height is allowed.

If the bumper heights are not within specification, the front springs must be changed to achieve compliance.

### Crown Victoria Bumper Heights (at curb weight)

Front	Rear	Tolerance
15.5 in.	15.3 in.	+/-1 in.

# SECTION 2

## 2004 Police Interceptor Modifier Guide

### Contents

Section 2: Wiring.....	2-1
General Guidelines.....	2-1
Available Power Sources .....	2-14
How To Change Option Content.....	2-20

## Section 2: Wiring

### General Guidelines

- Circuit protection (fuses) must be provided for all wiring. The fuse rating should not exceed either the rated wiring current capacity or the total current requirements for all the add-on components on the circuit. Fuses should be installed as close to the point of tapped power as possible.
- All revisions to the electrical system should be documented and placed with the vehicle owner guide. All revisions or additions to wiring should be color coded and/or labeled.
- Protective covering should be provided in all areas that could be damaged during normal equipment installations.
- Vehicles stored on site should have the negative battery cable disconnected to reduce the possibility of draining the battery by lights or other equipment.
- Control panels attached to the instrument panel should not protrude into the driver and passenger air bag deployment zones. For additional information, refer to Section 4: Installation Considerations in this guide.
- Switches and gauges should not be installed in the driver or passenger knee impact areas.
- All Ford gauges, lights, and switches must be inspected for correct operation after instrument panel work is performed.
- All wiring relocated or removed while working behind the instrument panel must be secured properly to prevent chafing, squeaks and rattles.
- Provide adequate retention for wiring harnesses so that they are clear of bolts, corners, edges, etc., which could abrade the wires during normal vehicle operation.
- Anticipate misrouted wiring situations and protect all wiring from penetration by screws and raw edges.
- Weather-seal all electrical connectors exposed to the elements.
- Do not use quick splice connectors or wire nuts.
- Install the fuse panel so fuses are readily accessible.
- Connections should be easily accessible for assembly and service.
- Make sure submersible connectors do not lose their seals under extreme assembly conditions, such as bending wires 90 degrees immediately after the connector.
- Whenever using connectors, use a socket (female) connector on the electrical source side and a plug (male) connector on the electrical load side to reduce the possibility of a short circuit when disconnected.
- Air bag restraint systems must remain intact as received from Ford Motor Company. Before modifications are done to the vehicle, the system must be disarmed by following the instructions provided in the current Crown Victoria Workshop Manual.
- Adherence to the above guidelines is not to be construed as approval by Ford Motor Company of any specific revisions or additions to the vehicle's original electrical system.

## Section 2: Wiring

### Isolate The Systems

When installing multiple police equipment components, it is advisable to use separate electrical systems. This will minimize confusion and ease troubleshooting. The front power distribution box and the optional rear power distribution box each have 3 relays and 10 fuses available for the addition of police equipment. Distribute loads among these circuits appropriately to help avoid an imbalanced system.

### Keep-alive Power

The electronic engine and transmission control modules require battery power to be supplied at all times to maintain the keep-alive memory. Keep this in mind when installing load disconnect switches or solenoids.

### Equipment Grounding Guidelines

- Do not ground the body to the transmission or transmission crossmember. Accessories must be grounded to the chassis or the vehicle battery.
- Splicing into circuitry relating to the electronic engine and/or transmission control systems is not acceptable because of the adverse effect on the electronic system operation.
- Electrical connections exposed to the elements should be appropriately protected.

### Wire Insulation

- Polyvinyl Chloride (PVC) rated at 90°C (199°F) is the standard wire insulation that is acceptable for inside body use but is not acceptable for underhood/underbody wiring.
- Hypalon insulation should be used on links only (Ford Specification ESB-M1L54-A).
- Cross-linked Polyethylene (XPLPE or SXL) rated at 135°C (275°F) is the required insulation for underhood/underbody applications (Ford Specification ESB-M1L123-A).
- GXL can be used as an alternate wire (Ford Specification ESB-M7L85B) as long as the concentricity specifications are met. To provide a water-resistant seal in conjunction with crimp connectors, a Duraseal crimp connector is recommended since it is designed to account for outside wire diameter that is smaller than the present SXL wire.

### Terminals and Connectors

#### Connector Types

- Submersible (Sealed) — A connector that is capable of being immersed in water.
- Weather-resistant — A connector that will retain its sealing and connection qualities while being exposed to adverse weather conditions.
- Duraseal crimp — A supplier trade name for a sealed wiring repair or splice.



## Section 2: Wiring

When a connection is not defined (typical situation - harness to harness connectors), the following suggestions should be implemented:

- Determine the connector type. If it will be located in a hostile environment, use a sealed connector; if not, use an open connector. A hostile environment is defined as being exposed to water and/or salt accumulation and/or high temperatures (i.e., underhood, exterior panels and footwells). Use in-line connectors with secondary locks to prevent the terminal from being pushed out.
  - Do not use single wires smaller than 14-gauge in a 2-way or larger weather resistant connector (the very-large style), since the wire may break during disengagement.
  - Use Hypalon, XLPE or Elexar insulation in submersible connectors to maintain sealing integrity. PVC is not acceptable because it cold flows and allows setting in a deformed pattern, therefore compromising the integrity of the seal.
- Determine the terminal type. Base your decision on wire gauge, current carrying capacity, connector type and insulation type.
  - Use non-detent low insertion force terminals whenever possible.
  - Do not use low insertion force female terminals in weather resistant connectors.
  - Analyze circuit requirements (signal levels, current, voltage, etc.) to determine the proper plating material (such as gold). Use of unplated terminals is not recommended.
  - Do not use plugs to seal holes in micropin connector grommets. It is very easy to forget to insert them during manufacturing and ruin the seal. Use a grommet with only the necessary number of holes or use dummy wires at least 600 mm (24 inches) long.
  - Fully align connectors prior to terminal connection -- terminal cavities should have minimum tolerance to prevent terminals from floating, bending or pin pushout during mating/engagement.
  - Make sure connectors of similar type and color are identifiable to the operator to eliminate crossed connections and minimize assembly time. Avoid using similar types and colors of connectors close together.
  - Be sure that connectors have positive locking devices that allow easy installation with a low insertion force and easy removal. The connector snap should be easily felt and heard.
  - Eliminate the use of edgeboard, tang-type, and molded-over connectors. The use of blade-type weather resistant connectors is restricted to high current applications which cannot be handled by submersible connectors.

### Circuit Protection and Electrical Load

- Modification to existing vehicle wiring should be done only with caution and careful consideration of effects on the completed vehicle's electrical system. Anticipated circuitry should be studied to determine the required circuit protection and to avoid feedback loops.
- Added circuitry must be protected either by a base vehicle fuse or circuit breaker, or by a similar device supplied by the modifier.

## Section 2: Wiring

- When adding loads to a base vehicle-protected circuit, make sure that the total electrical load through the base vehicle fuse or circuit breaker is less than the device's load rating.
- Use 80 percent of the fuse rating to determine maximum steady state load to reduce nuisance fuse failures.
- Use 135 percent of the fuse rating when sizing wiring to protect the circuit in the event of an overload. Fuses will last for one hour at 135 percent of their rating.
  - Total current draw is the sum of the base vehicle's circuit current requirement (measured with an ammeter) and the anticipated add-on component current requirements.
  - Never increase the rating of a factory installed fuse or circuit breaker.
  - If the total electrical load including additional electrical components, on any circuit, is less than the fuse protection rating or the capacity of some limiting component (switch, relay, etc.), the items to be added can be connected directly to that circuit. The headlamp switch circuits should never have additional lighting or electrical components directly connected.
  - Added devices that exceed the current capabilities of the factory-installed system are best controlled through the use of a relay or separate switch. The coil of the relay can be fed from the circuit in the factory harness (now acting as a signal circuit) with added wiring providing feeds to the added electrical device. The relay selection is important and depends on current requirements, number of cycles expected in the relay lifetime, whether the relay is to be operated intermittently or for long periods of time, and whether the relay is exposed to weather conditions or is installed in a protected area. When the current requirements of a circuit exceed the capacity of an available relay, the load should be reduced or divided through the use of additional relays.
  - Added wire feeds to the switch or relay power contacts should not be tapped into the basic vehicle wiring. Use the standard Auxiliary Power Distribution Box, or draw power as close to the battery as possible.

### Grommets and Sealing Requirements

Any additional wiring routed through sheet metal must pass through a grommet that both seals the opening and locates the wire(s). Two-piece grommets (plastic inserts with rubber outers) are recommended to facilitate installation and retention.

- Locate grommets so they are accessible for proper seating (achieved by pulling) in sheet metal holes.
- Ramp grommets at the insertion end to facilitate installation and sealing.
- Be sure that the direction of the hole punch is in the direction of grommet seating and the hole is burr-free.
- Make sure the grommet molding compound will adhere to the harness to prevent slippage.
- Make sure the grommet will withstand the environment (temperature, splash, etc.).

## Section 2: Wiring

- Be sure that holes are large enough to allow the installation of the harness without causing circuit damage.
- Use adhesive tape on main trunks or branches with at least a 50 percent overlap to prevent wicking through grommets. Be certain to diaper-wrap the takeouts.

### Wire Routing

**⚠ WARNING: DO NOT PLACE ELECTRICAL COMPONENT ATTACHMENTS OR GROUND SCREWS ADJACENT TO VEHICLE FUEL TANKS, FUEL FILLER PIPES, FUEL LINES, FUEL VAPOR LINES OR CARBON CANISTERS. FAILURE TO FOLLOW THESE INSTRUCTIONS MAY RESULT IN PERSONAL INJURY.**

Wire harness routing should conform to the following:

- Wires routed through holes in sheet metal or castings must be protected by a grommet whether or not conduit is used (see figure below).

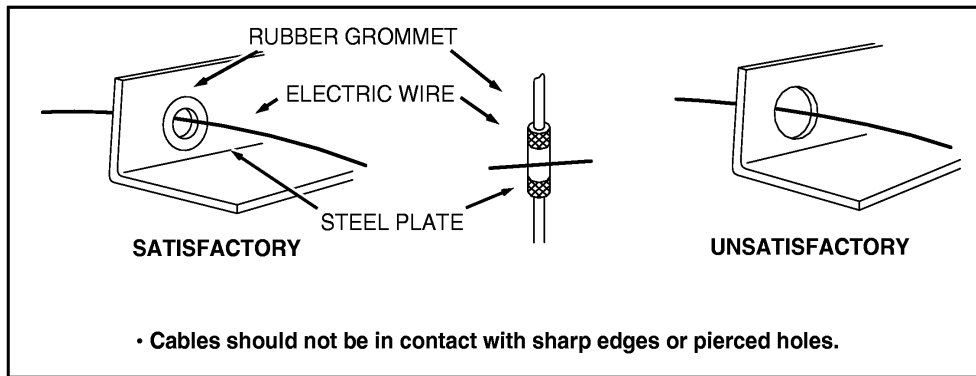

A0073515

- Wires should be routed to avoid metal edges, screws, trim fasteners and abrasive surfaces. When such routings are not possible, protective devices (shields, caps, etc.) must be used to protect the wires. Metal edges should be covered with a protective shield and the wiring fastened within three inches on each side of the edge (see figure below).

## Section 2: Wiring

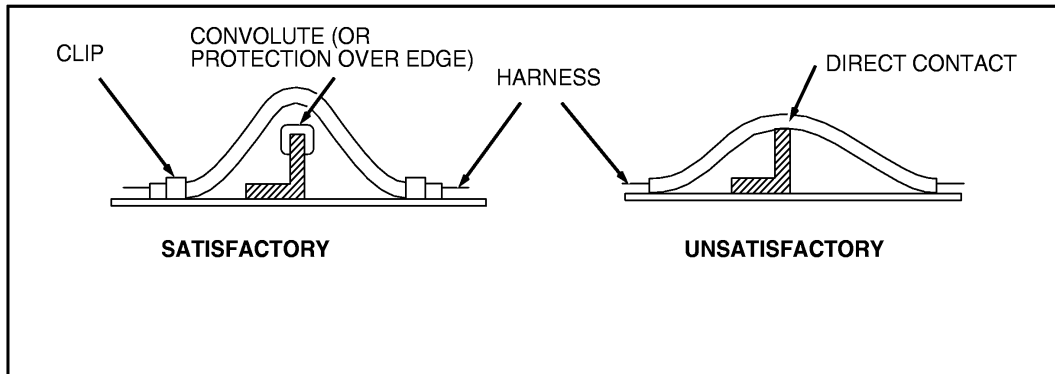

A0073514

- Wires must be routed to provide at least three inches of clearance to moving parts in their extreme movement location, unless positively fastened and protected by a conduit.
- Wire routings without conduit should avoid areas where temperatures exceed 82°C (180°F). Minimum clearance of six inches should be maintained from exhaust system components. Heat insulation and heat shields should be used on the wires routed in high temperature areas.
- Make certain that all underhood or underbody wiring is cross-linked polyethylene high temperature insulation wire 135°C (275°F) (minimum rating) consistent with SAE specification J1128 Type SXL wire. Normal PVC wire must not be used in underhood or underbody applications.
- Make sure all ground locations are readily accessible for installation, service and verification.
- Do not place ground attachments in high-splash areas.
- Do not route underbody wiring over the exhaust system.
- Underhood/underbody wiring must be routed in conduit for protection. Minimum conduit rating is 177°C (350°F).

### Wire Retention and Routing

Use the following criteria to determine the location of retainers:

- Size and weight of wire bundle.
- Holes with poor accessibility that prevent installation of locators.
- Movement of wires that can result in abrasion, squeaks and rattles.
- When wiring is routed between two members where relative motion can occur, the wiring should be secured to each member with enough wire slack to allow flexing without damaging the wire.
- Wiring exposed to weather must provide a drip loop to prevent moisture from being conducted into the device through the wire connection (see figure below).

## Section 2: Wiring

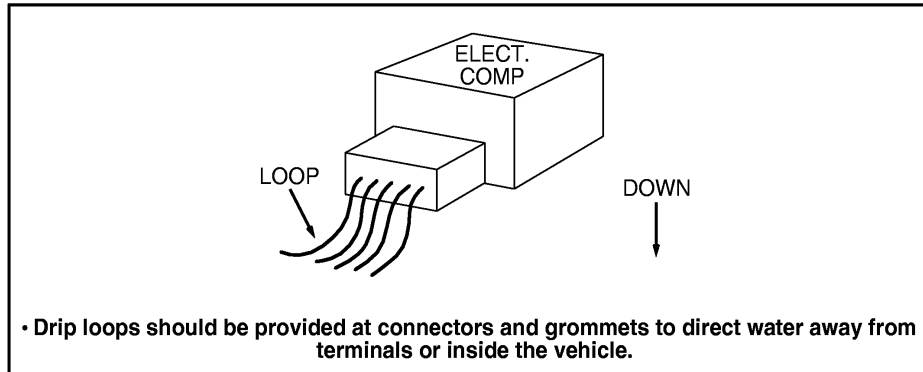

A0073517

- Routing wires into areas exposed to wheel splash should be avoided. When such routings cannot be avoided, adequate clipping and/or protective shields are required to protect the wires from stone and ice damage. Allow adequate slack in wiring between the engine and stationary components to compensate for engine roll.
- Routing wires under the frame side members or at points lower than the bottom frame flange is not recommended.
- Use plastic “zip” straps for “bundling” only (securing to other wires).
- The wire retainers and grommets installed by the assembly plant are usually designed to accommodate only the Ford-installed wires. Additional wiring or tubing should be retained by additional clips. When added wires or tubes are routed through sheet metal panels, new holes with proper wire protection and sealing must be used (see figures below).

## Section 2: Wiring

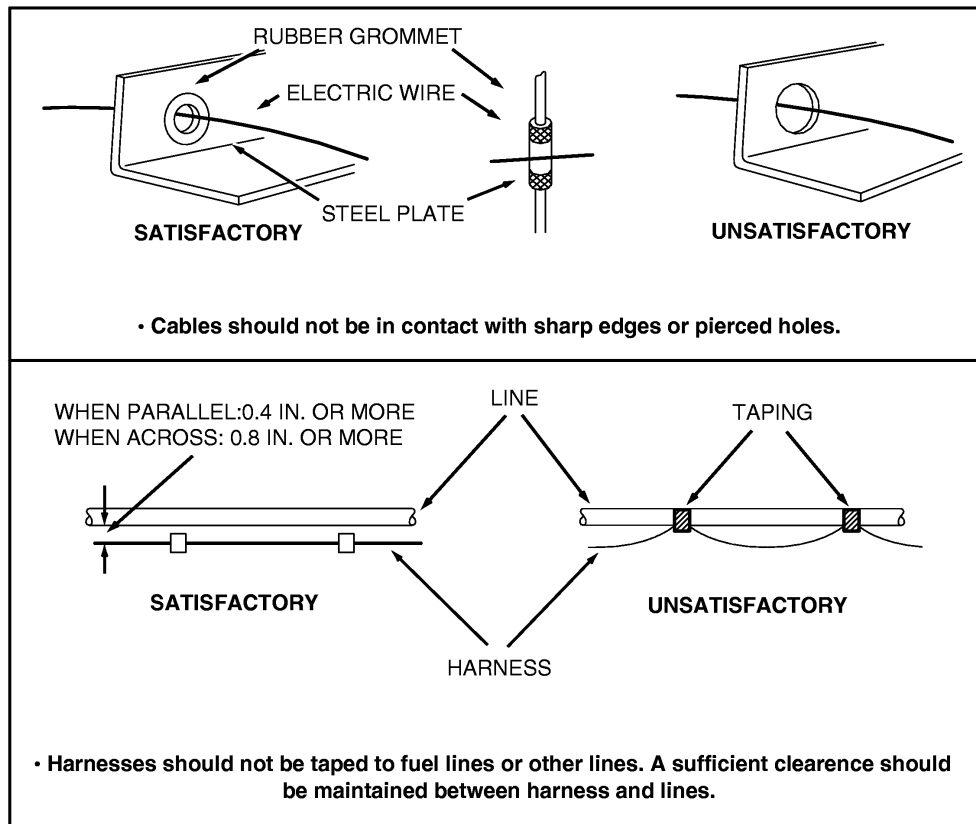

A0074038

For retainer screws, the following guidelines apply:

- Avoid using fasteners that are too long for the application or are in an area which might damage vehicle components, including wiring, brake lines, fuel tank and lines, powertrain components, exhaust system, and suspension.
- Do not use pointed screws for attachments. Also check that screws used in the vicinity of the wiring are blunt-ended.
- To minimize the potential for wiring shorts do not use drill point screws. Trim components (including wiring shields) should use pin-type attachments instead of screws.

## Section 2: Wiring

- Always check areas that screws protrude into for verification that an interference condition to other components does not exist.
- Make sure that retainers used are capable of withstanding the environment over the vehicle's life expectancy.

### Splices and Repairs

For quality splicing and to reduce potential problems, the following guidelines are recommended:

- Stagger the splices within a harness to reduce increased harness diameter. Splice only on straight areas as installed, not on bends.
- Strip wire ends making sure that individual conductor strands are not damaged.
- When soldering, make sure an adequate mechanical joint exists before applying solder. Use only resin-core solder. Acid-core solder should not be used since it may result in corrosion.
- For crimp joints, use butt-type metal barrel fasteners and the proper tool at the appropriate setting for the wire size (such as Motorcraft crimp tool S-9796) specifically designed for this type of work.
- Make sure splice joints are adequately sealed and insulated. In an outside environment, use Duraseal butt connectors or equivalent. A durable substitute splice joint can be achieved by using a bare metal barrel, crimping, flow-soldering and covering with shrink tubing (see figure). Quality electrical tape can be used inside the vehicle but is not recommended for an outside environment.
- Be sure that the new wire is not a lesser gauge than its original mating wire.

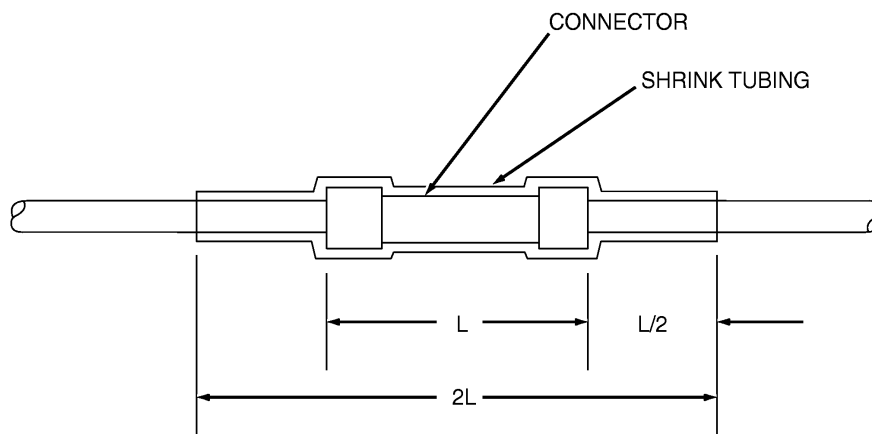

A0074039

### Recommended splicing method

1. Disconnect the battery.

## Section 2: Wiring

2. Strip wires to appropriate length.

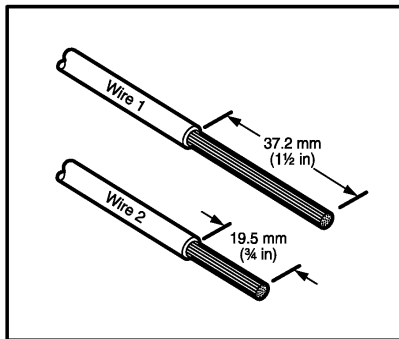

A0075761

3. Install heat shrink tubing.

4. Twist wires together.

Note: Use resin-core mildly-activated (RMA) solder. Do not use acid-core solder.

5. Solder wires together.

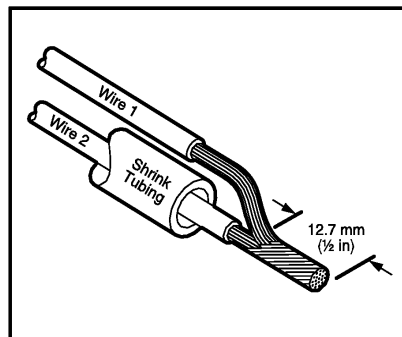

A0075762

Note: Wait for solder to cool before moving wires.



## Section 2: Wiring

6. Bend Wire 1 back in a straight line.

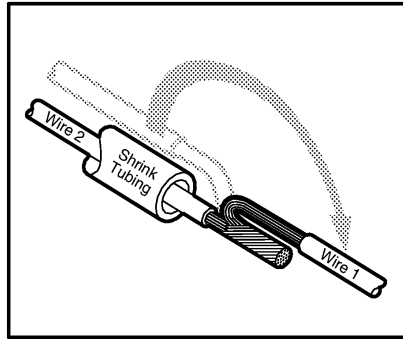

A0075763

Note: Overlap tubing on both wires.

7. Evenly position heat shrink tubing over wire repair.

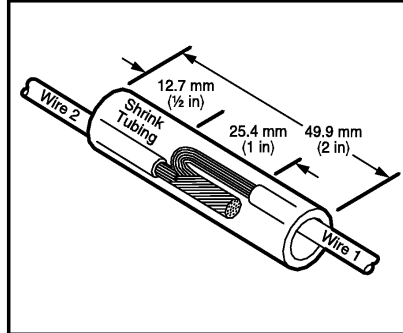

A0075764

8. Use heat gun to heat the repaired area until adhesive flows out of both ends of heat shrink tubing.

## Section 2: Wiring

9. Reconnect the battery.

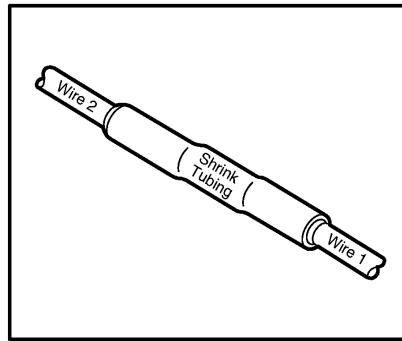

A0075765

### Sealed Connectors

Ford Part Number	Part Name	Class
E6FZ-14488-A	Butt Connector Gauge: 18-22, Color: Red	C
E6FZ-14488-B	Butt Connector Gauge: 14-16, Color: Blue	C
E6FZ-14488-C	Butt Connector Gauge: 10-12, Color: Yellow	C

Heat Shrinkable Tubing (Heat Shrink) (Ford Specification ESB-M99D56-A2)

Heat shrinkable tubing is available in various diameters for different splice sizes and configurations. When shrunk, it forms a small, flexible hermetic seal.

Other methods (tape, PVC mold, etc.) do not provide a hermetic seal and are not recommended. Splice balancing is critical with heat shrink insulation. If the splice is extremely unbalanced (more circuits on one side than the other), heat shrink insulation will not provide a proper seal. Evaluate the use of double terminals instead of splices where practical in these situations.

### Wire Protection Requirements

General Notes:

- Anticipate problems and design accordingly. Try to anticipate what could go wrong and modify your designs to address any adverse impact.
- Review all connector applications and electrical systems to determine the need for solder, grease, weather-resistant or sealed connectors. Make sure components and wire insulation are compatible with greased connectors (important for long term durability).
- Make sure that drip loops or other means are provided to prevent water leakage into the vehicle through wiring assemblies that pass through the dash panel.

## Section 2: Wiring

- Use greased or sealed connectors in floor pan troughs which are subject to moisture coming through the carpeting.
- Use XLPE insulation for uncovered runs that exceed 305 mm (12 inches).

### Electrical Protection

- Properly route wires away from noise-generating wires or components. However, if routing near noisy wires or plugging into noisy components is unavoidable, additional protection must be designed into the harness.
- Shielding — Electro Magnetic Interference (EMI) — Consider shielding if you must route close to high-current or noisy circuits. Use shielded wire and ground one side. Seal all splices in wire assemblies that use bare coaxial shielding (braid or tape) for EMI suppression, and insulate or tape over all shielding ends that terminate near any open connectors. This prevents splice and terminal shorts to the shielding. Minimize the length of conductors which extend beyond the shield. Failure to do this reduces the effectiveness of the shield.
- Spike suppression, in general, is accomplished by connecting a diode or resistor-diode combination across the terminals of the noisy component. The diode should be sufficiently close to the component (both electrically and physically) so that inductive spikes are clamped off. Make sure the diode is connected with the proper polarity.

Proper routing and retention will reduce the likelihood of chafing, pinching, etc. When this ideal routing is unattainable, the following additional protection is needed:

### Mechanical/Environmental Protection

- Tape — Tape is the most basic means of protection. It contains the wires in a loose bundle and provides limited environmental protection. It does not protect against chafing and pinching.
  - Kendall Polyken Fiberglass Base Tape (Ford Specification ESB-M3G38-A) is used for engine compartment applications. This durable tape provides against cut-through and abrasion commonly found in underhood applications.
  - Polyken 267 is a substitute tape that may be used in lower temperature areas of the engine compartment (apron area).
- Convolute - Use convolute for all underhood/underbody applications or when increased temperature, abrasion or pinch resistance is required. Convolute tubing comes in different diameters and materials to accommodate different temperature ranges and harness sizes.
  - Use polyethylene convolute when abrasion is the only consideration; this convolute is adequate up to 96°C (205°F) maximum. Use nylon convolute when underhood/underbody or abrasion and temperature are considerations; nylon convolute is adequate up to 177°C (350°F) maximum.
  - On all engine-mounted wiring or bend points. Use vinyl tape on the outside of the convolute to prevent wiring from looping out. This tape must be able to withstand high temperatures 135°C (275°F) or over.
  - Tape convolute junctions with a abrasion-resistant tape (Polyken 267, fiberglass, etc.).

## Section 2: Wiring

- Scroll — Similar to convolute, but without the ridges. Scroll is used where harness rigidity is required, especially for maintaining critical locator dimensions. Use scroll for short lengths only, as it is quite inflexible.

Note: This is not meant to be an all-inclusive list of methods for physically protecting the wires. There are other means of protection available that are not listed.

### Available Power Sources

#### Front Power Access Point (C275)

The front power access point is a connector (C275) located below the glove box. This connector contains various power feeds and inputs available for the addition of police accessories. See the following illustrations and table for connector and circuit details. A mating connector with blunt cut wire leads is available from an authorized Ford Dealer with a base service part number of 14A411.

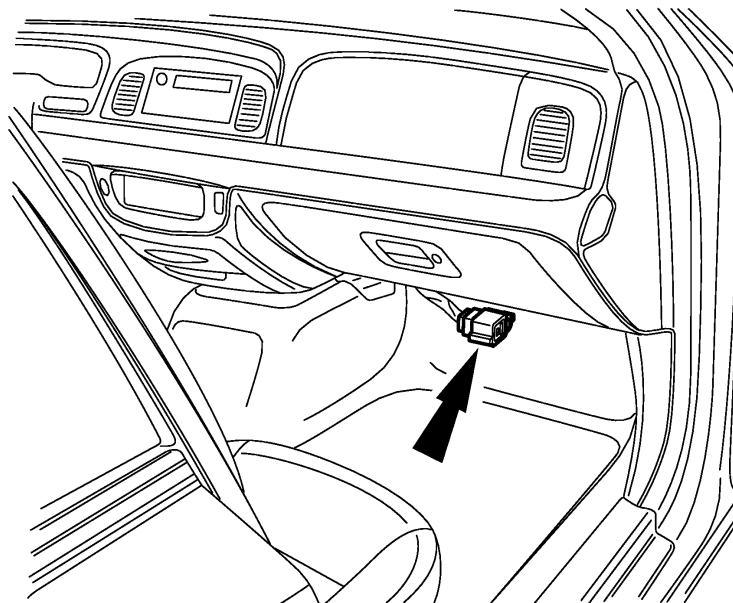

A0092210

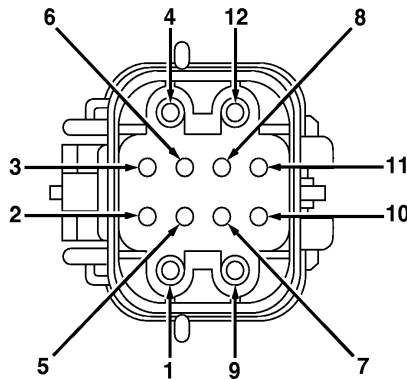

A0092211

## Section 2: Wiring

Cavity #	Circuit #	Gauge	Color	Function
1	792	10	TN/YE	Battery feed from battery junction box fuse #110 (50A)
2	385	16	WH/RD	Hazard in signal
3	175	18	BK/YE	Blunt cut to engine compartment
4	401	10	PK	Run/Accuracy feed from battery junction box fuse #111 (30A)
5	Empty	-	-	Empty
6	Empty	-	-	Empty
7	679	18	GY/BK	Vehicle speed signal
8	705	16	LG/OG	Battery save signal
9	3010	10	TN	Battery feed from battery junction box fuse #117 (50A)
10	689	18	DB	Start signal
11	44	16	LB	Hazard out signal
12	57	10	BK	Ground

### Front (Optional) Auxiliary Power Distribution Box

The Auxiliary Power Distribution Box contains the following:

- 30A supply circuit that operates when the vehicle is in the RUN or ACCESSORY position (Battery Junction Box fuse 111)
- 50A supply circuit connected directly to the battery (Battery Junction Box fuse 117)
- Ten (10) fuses of various amperages
  - Five (5) direct to the battery (total 50-amp maximum)
  - Five (5) through the ignition switch (total 30-amp maximum)
- Three (3) relays protected by 20A fuses
- Four (4) ground circuits

## Section 2: Wiring

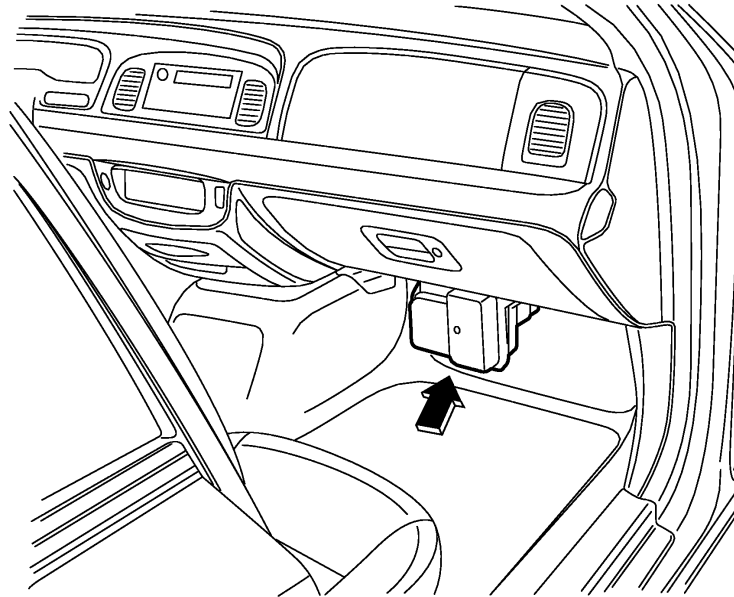

A0074040

### Rear Power Access Point

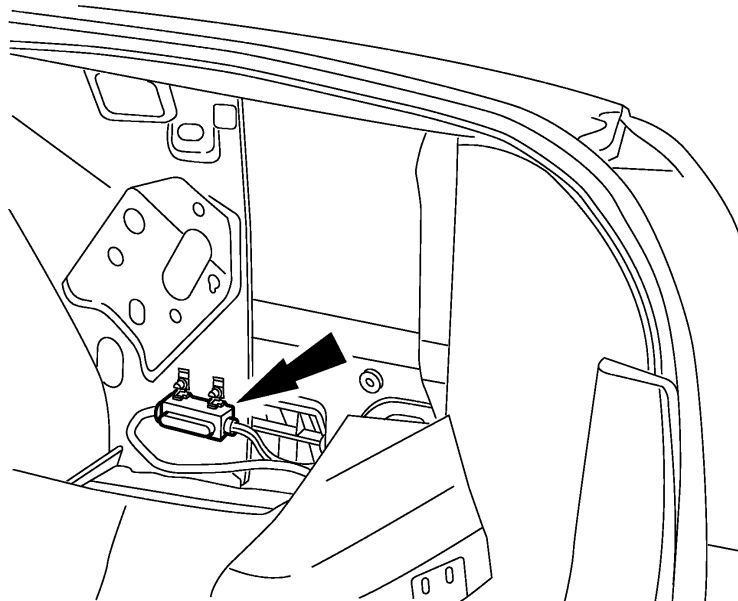

A0092207

## Section 2: Wiring

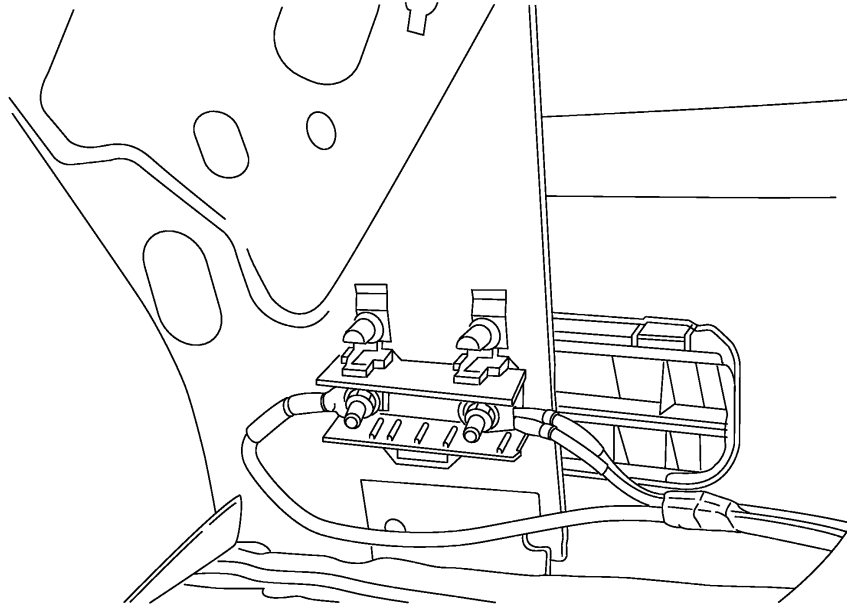

A0092208

**⚠ WARNING: UNDER NO CIRCUMSTANCE SHOULD THE REAR POWER ACCESS POINT COVER BE REMOVED WITHOUT FIRST REMOVING THE BATTERY JUNCTION BOX (BJB) FUSE #110 AND FUSE #117. REMOVING THE COVER WITHOUT REMOVING THE FUSES COULD RESULT IN AN ELECTRICAL HAZARD. TURN OFF LOAD DEVICES BEFORE INSERTING THE FUSES. FAILURE TO FOLLOW THESE INSTRUCTIONS MAY RESULT IN PERSONAL INJURY.**

The Rear Power Point is a battery access port for Police auxiliary equipment mounted in the trunk. It is capable of supplying 80 amps of battery power. The BJB contains two 50 amp fuses (#110 and #117) which protect the Rear Power Access Point. Battery access is provided by two studs contained in an enclosure, mounted in the trunk behind the carpet, on the right side fender support. The terminal with the red wire is the battery positive, and the terminal with the black wire is the ground. Remove both fuses in the BJB before removing the cover to the rear power point. Insure load devices can be turned off, and are switched off when reinserting the fuses.

## Section 2: Wiring

### Police Prep Packages (Optional)

Vehicles equipped with one of the optional Police Prep or Visibility Packages (options 65A, 68P and 65W) include a different Auxiliary Power Distribution Box that is located in the glove box or trunk. By checking the area of the glove box or trunk, it can be easily determined if a vehicle is equipped with a Police Prep and Visibility Package. The standard Front Auxiliary Power Distribution Box normally mounted below the glove box is deleted and the Police Prep and Visibility Package Power Distribution Box is installed inside the glove box or trunk. For additional information, refer to the Ford Police Interceptor Preparation Packages Owner's Manual that is included with the vehicle.

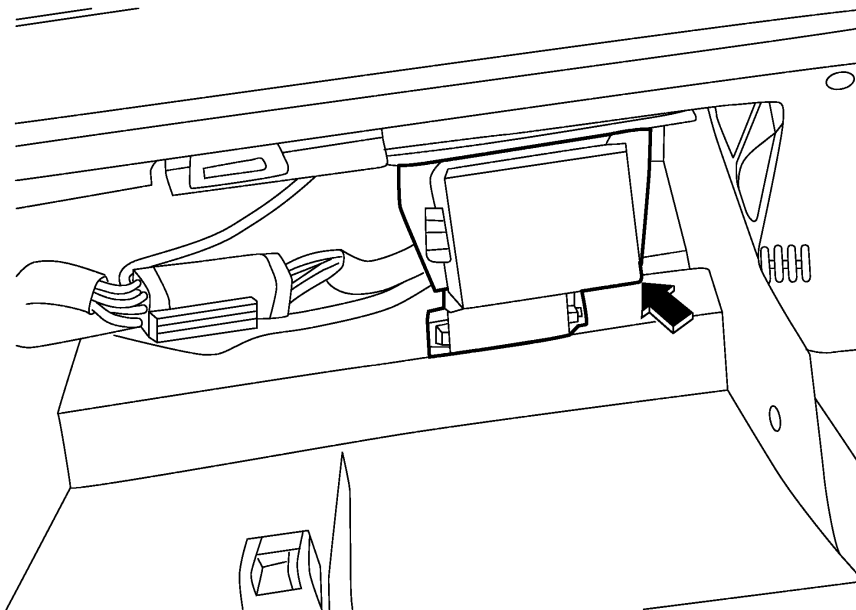

A0074657



## Section 2: Wiring

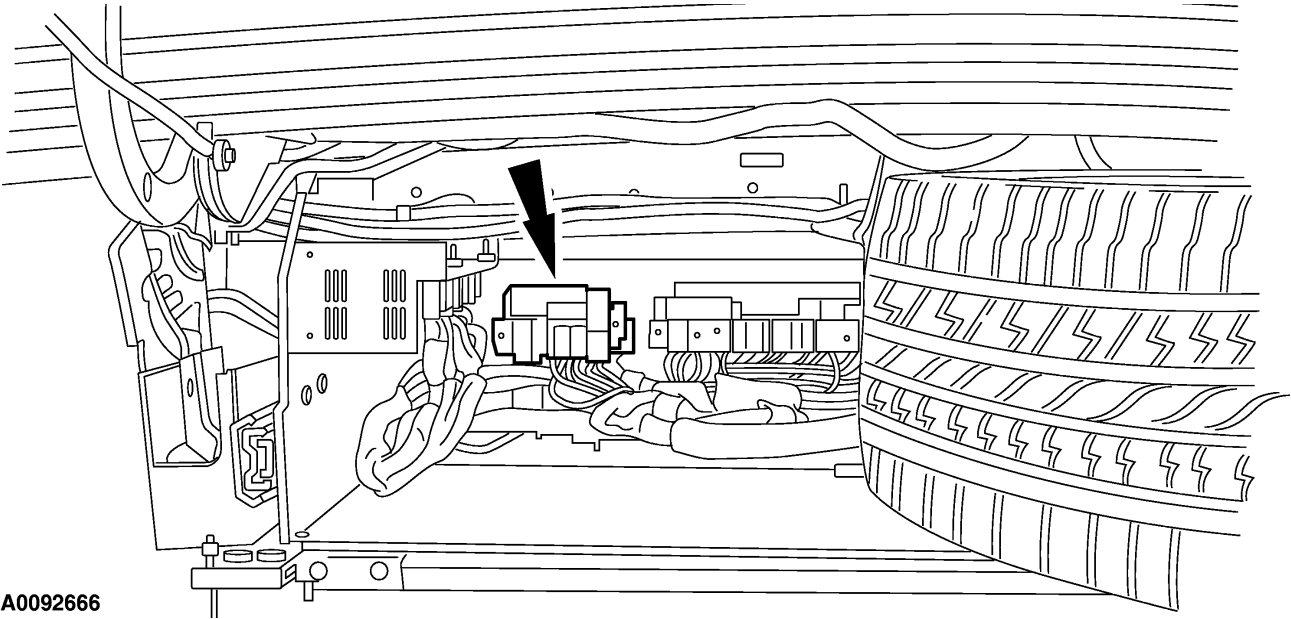

A0092666

### B-Pillar Light Bar Connector

In the lower right hand B-pillar (behind the B-pillar trim), there is an available power source (light bar connector C300). This is a 4-pin connector with three (3) circuits. One fused circuit (50 amp) from the BJB fuse 109 and two (2) ground circuits. See the following chart for connector information:

Pin	Wire Color	Description
2	RD/YE	Hot at all times
3	BK	Ground
4	BK	Ground

## Section 2: Wiring

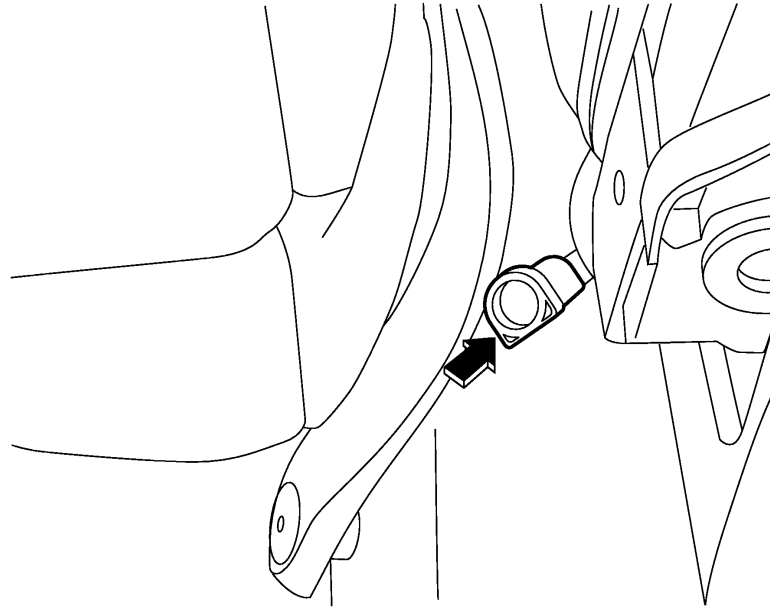

A0074042

### How To Change Option Content

#### Decklid Release Switch

The decklid release system may be configured to operate either when the ignition key is in the Run/Accessory position or at all times (without requiring a key). Configuration of the decklid release switch is accomplished by connecting one of the two available connectors located behind the dash trim panel. One of them is wired for power at all times and the other is wired for power only when the ignition key is in the Run/Accessory position.

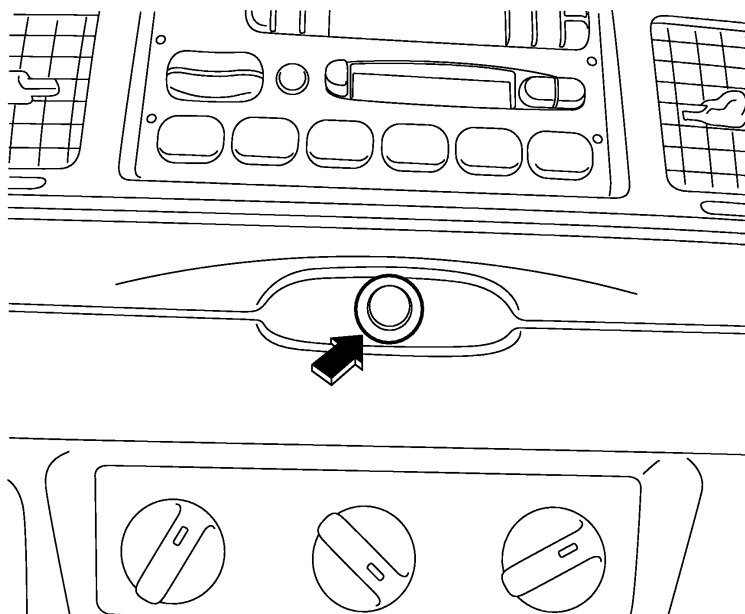

A0074045

## Section 2: Wiring

Use the following steps to change this option:

- Remove the dash trim panel by gently pulling to release the nine (9) push-type retainers.
- Disconnect decklid release switch electrical connector.
- Locate and connect the alternate decklid release switch electrical connector.

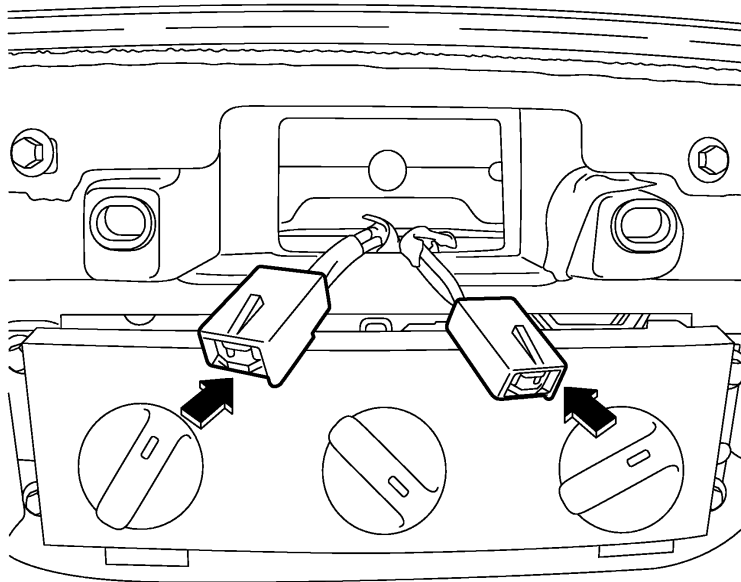

A0074046

Note: The connectors can be identified by the wire colors. The connector with the (VT/YE) and (BK/WH) wires has power at all times. The connector with the (VT/YE) and (YE/GN) wires has power in the run position.

- Reinstall dash trim panel.

### Courtesy Lamp Disable (Dark Mode)

This option offers deletion of the illuminated entry function. Upon vehicle power-up, the Lighting Control Module (LCM) will monitor the dark car input signal for a ground condition of longer than two seconds. If the ground is present, no interior lighting will be provided during entry or exit of the vehicle. The interior lighting will, however, still operate on demand whenever the dome lamp switch is active. A ground will be provided to the LCM by an in-line connector within the unique police 14401 instrument panel harness. The male terminal side connector will be retained on a portable clip and the female terminal connector will be tear-taped to a bundle. If the dark car feature is necessary, the connection will be made on the assembly line. If no connection is made the default state of the LCM will be to provide illuminated entry. The vehicle can be reconfigured by removing the power to the module, changing the dark car input from (or to) a ground or an open circuit, and then reapplying power to the module. The vehicle can also be reconfigured by changing the dark car input signal from (or to) a ground or an open circuit, entering diagnostics, and then exiting diagnostics.

## Section 2: Wiring

Use the following steps to disable the courtesy lamps:

- Disconnect the battery.
- Connect C263 - located under the glove box.

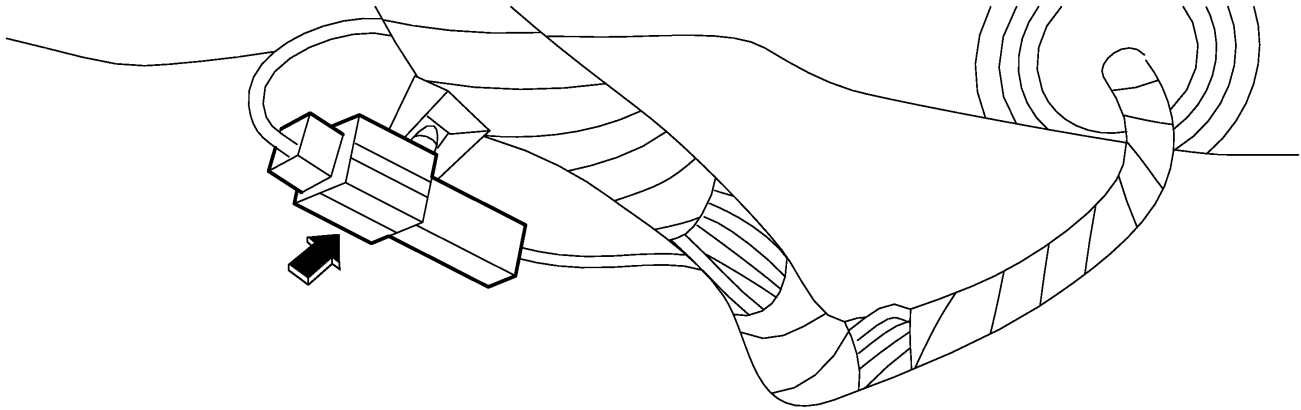

A0074044

- Connect the battery.

Use the following steps to enable the courtesy lamps:

- Disconnect the battery.
- Disconnect C263 - located under glove box.
- Connect the battery.

## Section 2: Wiring

### Rear Power Window Disable

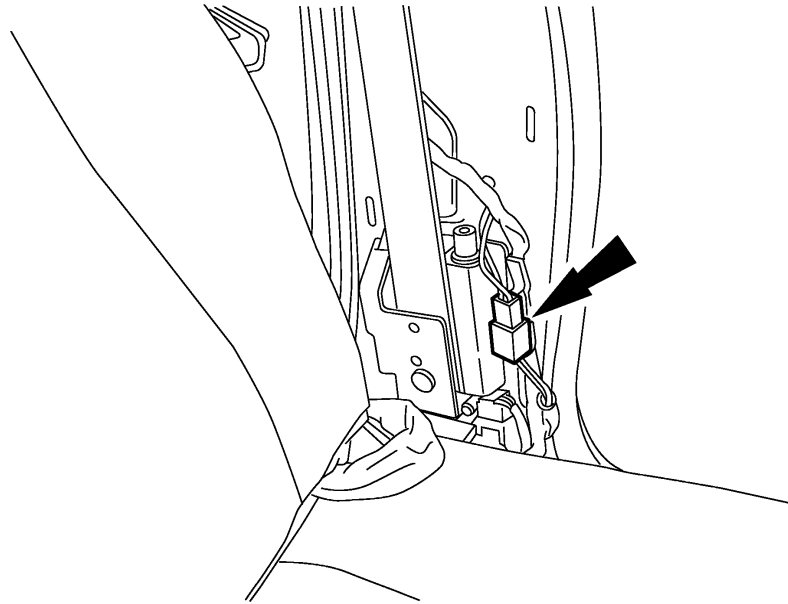

A0092209

The rear window control switches of the Crown Victoria Police Interceptor can be disabled by disconnecting the rear window power supply connector (C340). This connector is located behind the LH B-pillar trim panel, adjacent to the seat belt retractor. Disconnect the connector to disable the rear window control switches. While they are disabled, the master window control switch can still control the rear windows. Refer to Crown Victoria Wiring Diagram Manual for additional power window wiring information.

# SECTION 3

## 2004 Police Interceptor Modifier Guide

### Contents

Section 3: Electrical .....	3-1
Electrical Basics .....	3-1
Electrical Systems Management .....	3-2
Generator Output.....	3-2
Charging Margins .....	3-4
Powertrain Control Module — Red Area .....	3-5
Headlights and Tail Lights Modifications.....	3-5
Disabling Brake Lights.....	3-7
Vehicle Special Order (VSO) Options.....	3-8
Regular Production Options (RPO).....	3-10

## Section 3: Electrical

### Electrical Basics

Inside a vehicle, electricity is supplied through “hot” wires, comparable to the pressurized supply pipes of a plumbing system. At various points along the wires are outlets in the form of lights, switches, and receptacles. Turning on a light switch is somewhat like opening a faucet to let water run - an electric current flows through the hot wire to make the light glow. Once the electricity has done its work, its potential drops to zero, just as water loses pressure after flowing through a sink or laundry tub. And the electrical system has “drains” - the ground wires that return the current to its source just as a plumbing system has drain pipes through which water runs into the sewer mains or the ground.

The light or equipment powered by the current, technically called the load, can be compared to a water wheel that remains motionless until a stream of water causes it to turn. A load may be one of two kinds. The first consists of a resistance - a material that permits the passage of electric current, but only with difficulty, and thereby creates heat. The tungsten filament of an incandescent bulb is resistance; so is the heating element of an electric heater or a coffee pot. A load may also be an inductance - typically a motor with windings of copper wire, in which the magnetic fields generated by the current create motion. At any moment, the demand on an electrical system depends on the number of loads in operation and their consumption of energy, just as demand on a water system depends on how many faucets are opened and how wide they are opened.

The mechanics and physical fittings of the system are simple. Current moves throughout the vehicle in wires of different sizes, according to the current a circuit may have to carry. Power is supplied directly to equipment through connectors.

### Electrical Terms

**VOLT** is the unit that measures the potential difference in electrical force, or “pressure,” between two points on a circuit. The current at most points in the vehicle is 12.8 volts, although it may vary depending on the condition of the battery and the length and gauge of wire between the battery and the measurement point. As the current moves from the “hot” supply wire through the load presented by the light or equipment, it loses voltage doing work. When the current leaves the load and enters the return circuit provided by the ground wire, it has lost all voltage and is at zero pressure, the same as earth.

**AMPERE** is the unit used to measure the amount of current - that is, the number of electrically charged particles called electrons - that flows past a given point on a circuit each second. It is similar to measuring the amount of water flowing through a pipe at any given point. The larger the pipe is, the more water that can flow past the point per second. Similarly, the bigger the wire is, the more current that can flow through it at any given point. Current that has lost its voltage still has amperage as it completes the circuit and returns to the battery.

**WATT** is the unit of power. It indicates that rate at which a device converts electric current to another form of energy, either heat or motion, or to put it another way, the rate at which a device consumes energy.

## Section 3: Electrical

The relationship of volts, amperes, and watts to one another is expressed in a simple equation that enables you to make any calculations you may need for proper and safe electrical modifications to the vehicle. Volts x amperes = watts. If the current is at 12 volts and a device requires 4 amperes of current, the equation will read 12 volts x 4 amperes = 48 watts.

To figure the current needed for a device rated in watts, turn the equation around: Watts / volts = amperes. For example, if you have a piece of equipment, such as a communications radio, that uses 120 watts: 120 watts / 12 volts = 10 amperes.

### Electrical Systems Management

Care must be given in deciding what equipment should be installed into a police vehicle given the power demands of the equipment and the power available from the vehicle. A power load strategy should be developed to minimize the risk of running out of power. Examine the proposed equipment for vehicle installation. Add up the current requirements. If the current requirements exceed what the vehicle can reasonably be expected to be able to provide, the battery will begin discharging to provide the power to the equipment that the generator is unable to provide. After some period of time, the vehicle will shut off as the battery voltage decreases to a level that cannot sustain vehicle operation.

There are alternatives that can be considered to minimize system electrical overload. Consider the current requirements of equipment before it is purchased and installed. Modern light bars and radios use a fraction of the current that units made as recently as 1996. As the light bar is the most power intensive unit installed on most police vehicles, considerable attention should be given to its current requirements. Changes in officer habits while in the field can make a difference as well. When a vehicle is sitting at an accident scene and no one is in the car, the air conditioner can be turned off until the officer is ready to get back into the vehicle. The air conditioner is among the largest current user of non-police equipment. As such, it can impact available power for other uses as well.

### Generator Output

On all 2004 Police Interceptors, the generator is controlled by the Powertrain Control Module (PCM).

The Police Interceptor generator is different from that used on the standard Crown Victoria. The Police Interceptor has a 200 amp generator. This results in significantly greater current output, especially at idle where police vehicles need it most.

- Generator amp output.
  - Maximum output for the Base Crown Victoria is 135 amps.
  - Maximum output for the Police Interceptor is 200 amps.
- Generator drive ratio, determined by generator pulley size.
  - Base Crown Victoria 2.81:1
  - Police Interceptor 2.95:1



### Section 3: Electrical

- Faster idle speed.
  - Base Crown Victoria 600 RPM in park
  - Police Interceptor 800 RPM in park

Note: In order to calculate engine RPM from the graph below, divide the Generator Speed by 2.95 (or 3 as an approximate). Generator Speed / 3.0 = Engine RPM.

#### Generator Output

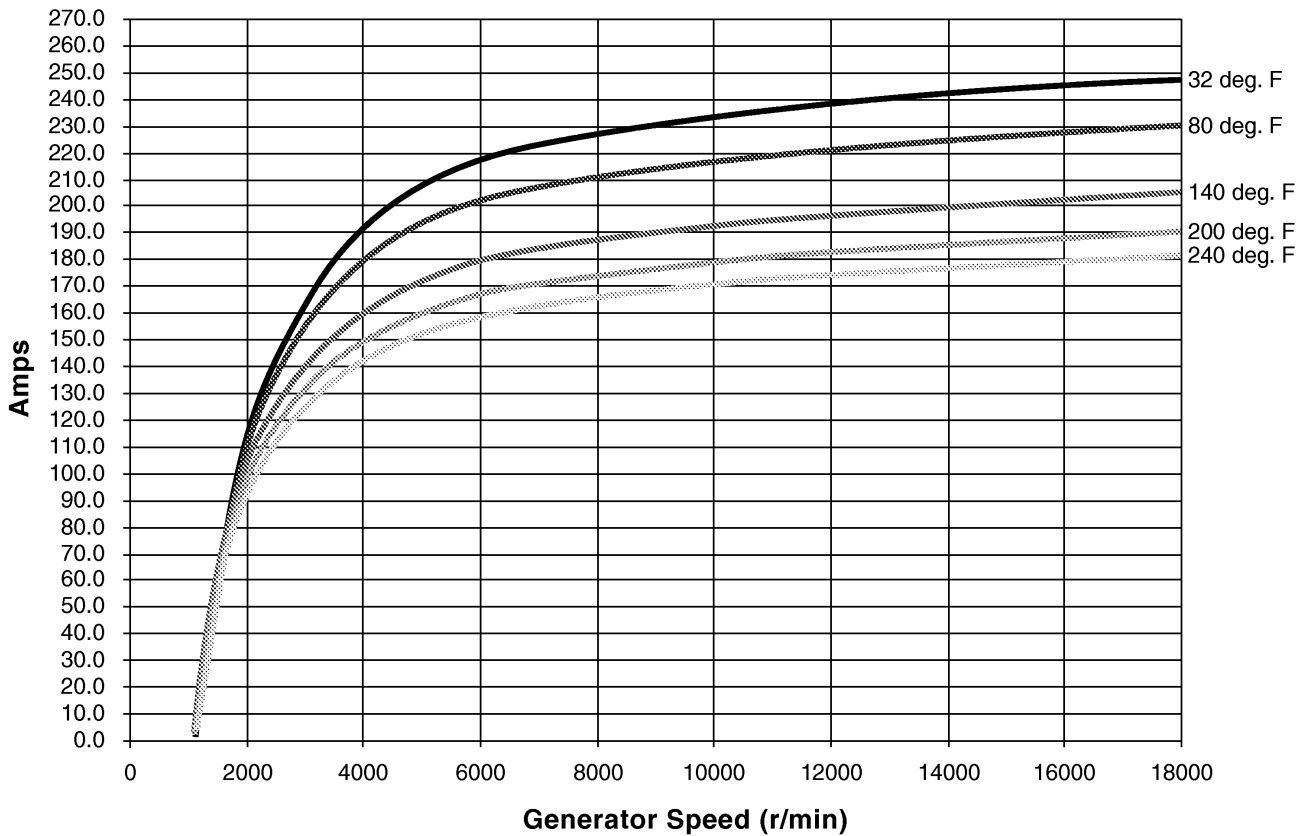

A0091619

## Section 3: Electrical

### Charging Margins

Generator output varies with engine speed and ambient temperature as it is illustrated in the Generator Output Section. The worst case for police vehicles is when the vehicle is idling for long periods of time on a very hot day. Lower engine speeds while idling, coupled with high underhood temperatures that may approach 200 degrees, combine to minimize power output from the generator. At the same time, electrical demand on the vehicle is often at its highest because the air conditioner loads are added to the usual electrical loads experienced in emergency situations.

### Vehicle Component Electrical Loads

Vehicle component electrical loads are shown in the table below. Note that not all features will be powered all the time, so actual vehicle loads on the power supply system will vary.

Component	Amps
<b>Base</b>	
Miscellaneous Base Loads	12.0
<b>Cooling</b>	
Cooling Fan (variable speed)	33.0
<b>Climate Control</b>	
A/C Clutch	3.7
A/C Fan to Face - High Speed (recirculating air)	15.1
A/C Fan to Face - M/H Speed (recirculating air)	8.5
Heater Fan to Foot - M/H Speed (fresh air)	8.9
<b>Lighting</b>	
Exterior and IP Lamps (non-dimmable)	5.6
Head Lamps - Low Beam	8.6
Head Lamps - High Beam (incremental)	1.2
Brake Lights (with CHMSL)	9.7
<b>Heated Features</b>	
Heated Rear Window (includes heated mirrors)	24.5
<b>Other</b>	
Radio	4.0
Speed Control	2.0
Wipers speed 1 (low)	1.2
Wipers Speed 2 (high)	2.5
<b>Typical Vehicle Load = 60 - 70 Amps</b>	

## Section 3: Electrical

### Typical Police Equipment

Loads for typical police equipment commonly found on police vehicles are shown in the table below. Note once again that not all equipment will be operating at the same time, so actual loads on the power supply system will vary.

Component	Amps
Communications Radio	4.0 (8.0 w/mic active)
Mobile Data Transmitter	3.0
Light Bar	28 — 43
Light Bar with All Internal Accessory Lights Activated	36 — 63
Spot Lights (each)	7.8
Alley Lights (each)	1.0
Radar	0.8
Camcorder	0.5

### Powertrain Control Module — Red Area

 **CAUTION: DO NOT make electrical connections to vehicle electrical systems not specifically designed for police equipment installations.**

Do not install any components into the Powertrain Control Module (PCM) or PCM harness. Connecting into this system may affect engine and transmission operation. As an example: connection of aftermarket electrical equipment into the brake light circuit or any other circuit which is connected to the PCM, anti-lock brake computer, air bag system or any other vehicle system will cause vehicle malfunction.

### Headlights and Tail Lights Modifications

 **CAUTION: Any Auxiliary Warning Lights, controlled by the Lighting Control Module (LCM), need diode protection to prevent current spike damage to the LCM.**

### Headlight Flashers (Wig-wags)

**Standard Feature** — An interfacing connector is provided on the headlight circuit for use of the headlights as alternating flashers (wig-wags). The connector is located at the front side of the radiator. There is a jumper connector attached that maintains proper headlight operation when a wig-wag module is not installed. When installing a headlight flasher (wig-wag) module, remove the jumper connector and tape it to the wig-wag module harness. This will ensure that the jumper is available to be reattached if the wig-wag module is removed. For additional information, refer to the Crown Victoria Wiring Diagram Manual.

## Section 3: Electrical

**Police Prep Option** — This option provides all the necessary components that will alternate the headlight high beams. The wiring is routed from the front side of the radiator to the right side of the engine compartment where the headlight flasher (wig-wag) module is located, then to the console area where the switch is located. This control switch is not a power source. It is a switching device that controls relays. For additional information, refer to the Ford Police Interceptor Preparation Packages Owner’s Manual.

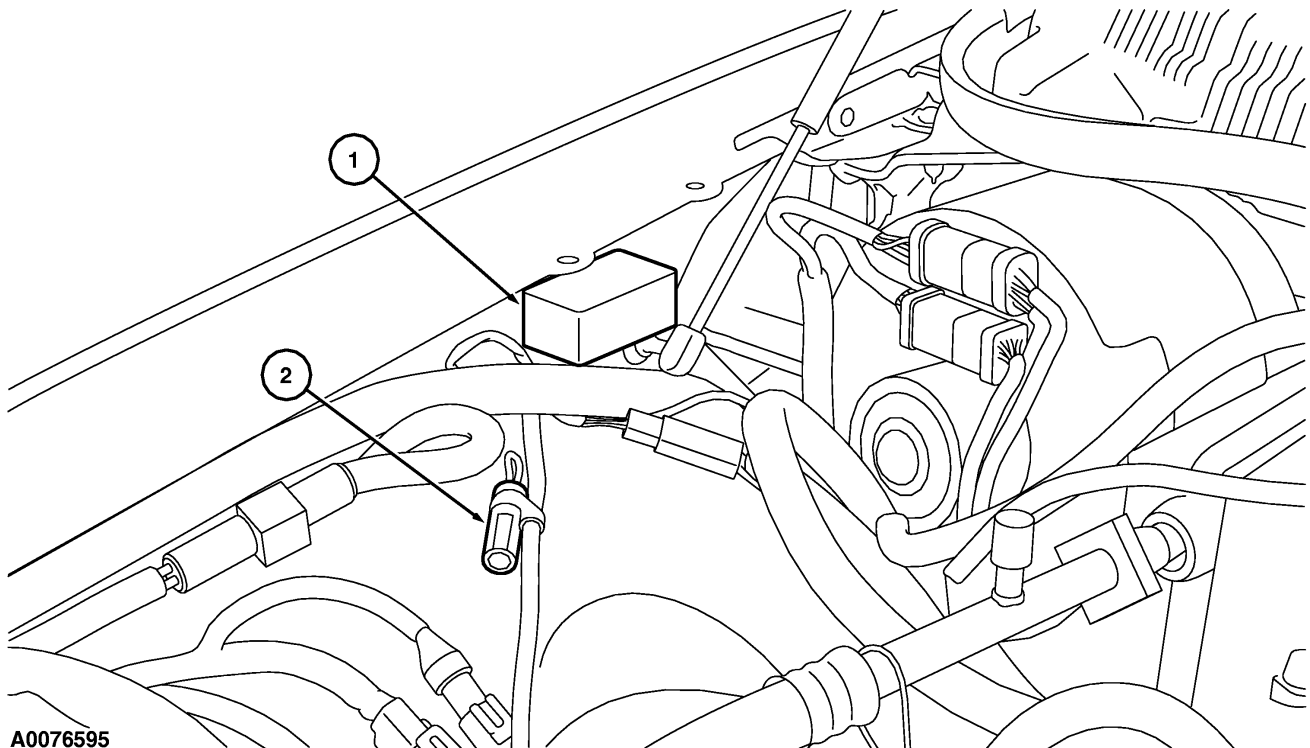

A0076595

Item	Description
1	Headlight flasher (wig-wag) module (Police Prep Packages)
2	Jumper connector (taped - not in use) (Police Prep Packages)

## Section 3: Electrical

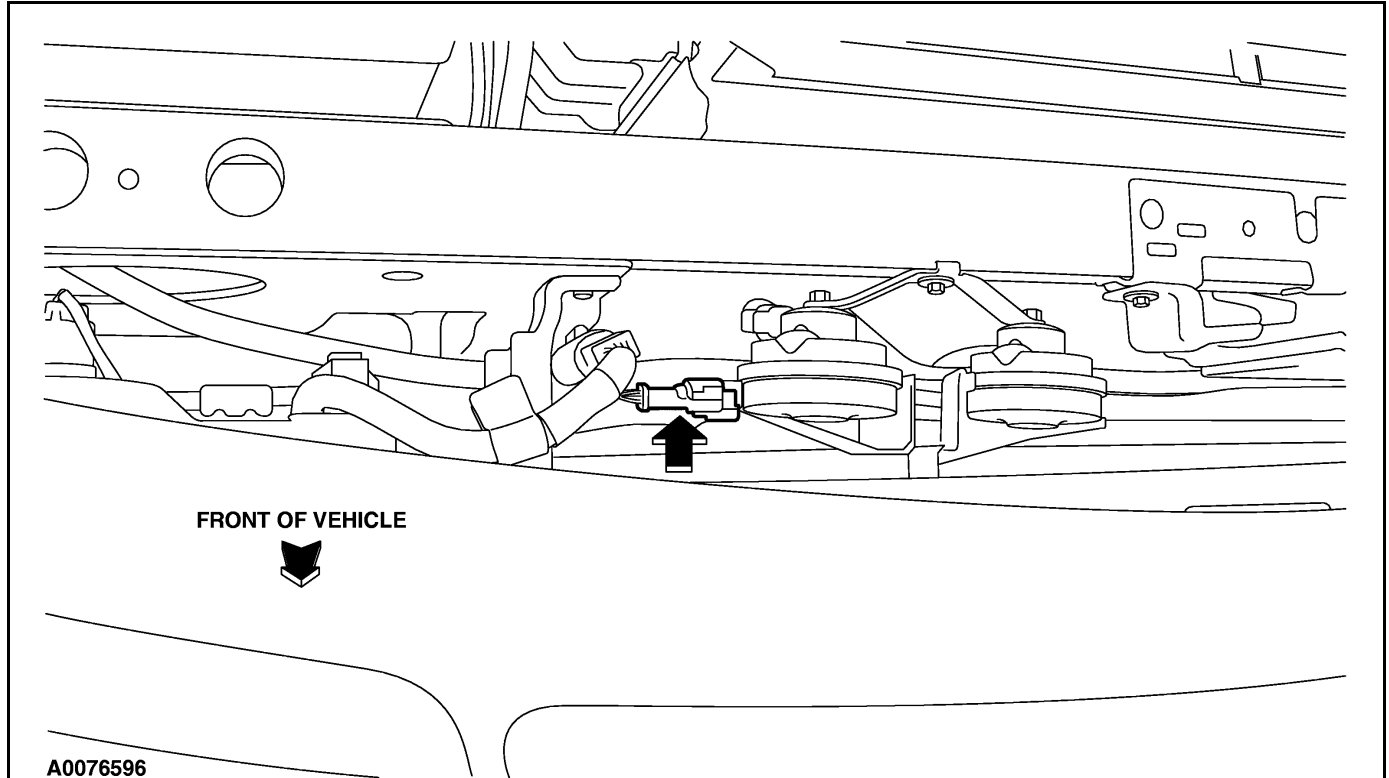

Head light flasher (wig-wag) module connector.

### Tail Light/Brake Light Flashers (Wig-wag)

Adding taillight flashers (wig-wags) to the brake light circuit requires that the splice location is inside the trunk area. Splicing into the brake light circuit at any other location will cause critical systems on the vehicle to malfunction. Circuit protection devices have been added to the vehicle to accommodate taillight flashers. These protection devices will only be effective if the taillight flasher (wig-wag) module is spliced into the section of the brake light circuit that is in the trunk area.

### Disabling Brake Lights

Do not disable the brake light circuits for any reason. For additional information, refer to Section 1: Safety Information in this guide.

## Section 3: Electrical

### Vehicle Special Order (VSO) Options

• **Horn/Siren Wiring** — This option includes a jumper harness that connects in-line to the horn connector that is at the base of the steering column. With this option installed, the horn button will activate the siren. There are four (4) connectors on this jumper harness. Two of them are 4-pin connectors and two of them are 1-pin connectors. The 4-pin connectors connect in-line between the steering column wiring harness and the instrument panel wiring harness. The 1-pin connectors attach to the siren.

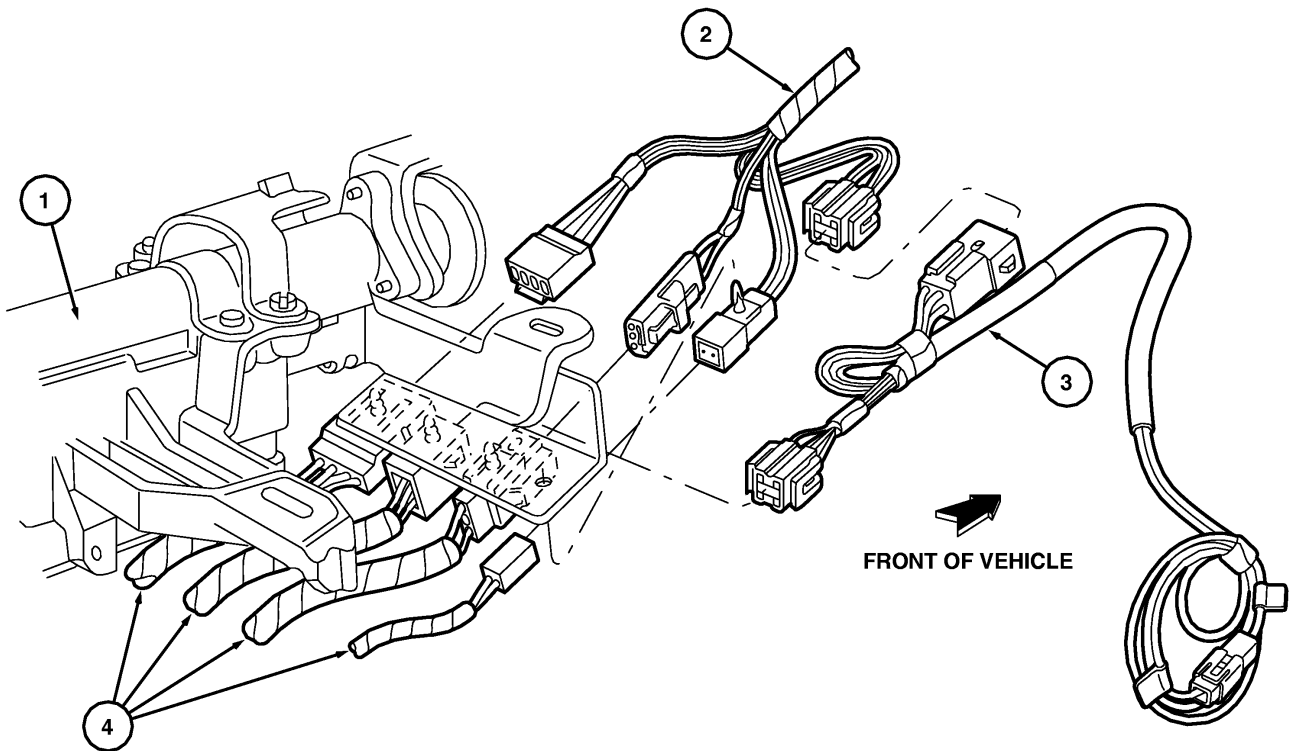

A0075766

Item	Description
1	Steering Column
2	Instrument panel wiring assembly
3	Horn/Siren wiring jumper harness
4	Steering column wiring harness

## Section 3: Electrical

- **Noise Suppression Filter** — The noise suppression filter option will help limit the amount of background noise that is sometimes heard in radios that is caused by the blower motor. This noise suppression filter connects in-line at the blower motor connector which is located on the side of the blower motor. There is a connector on either end of the filter. One of the connectors has an orange wire and a black wire, which connects to the blower motor. The other connector has a blue wire and a black wire that connects the blower motor harness.

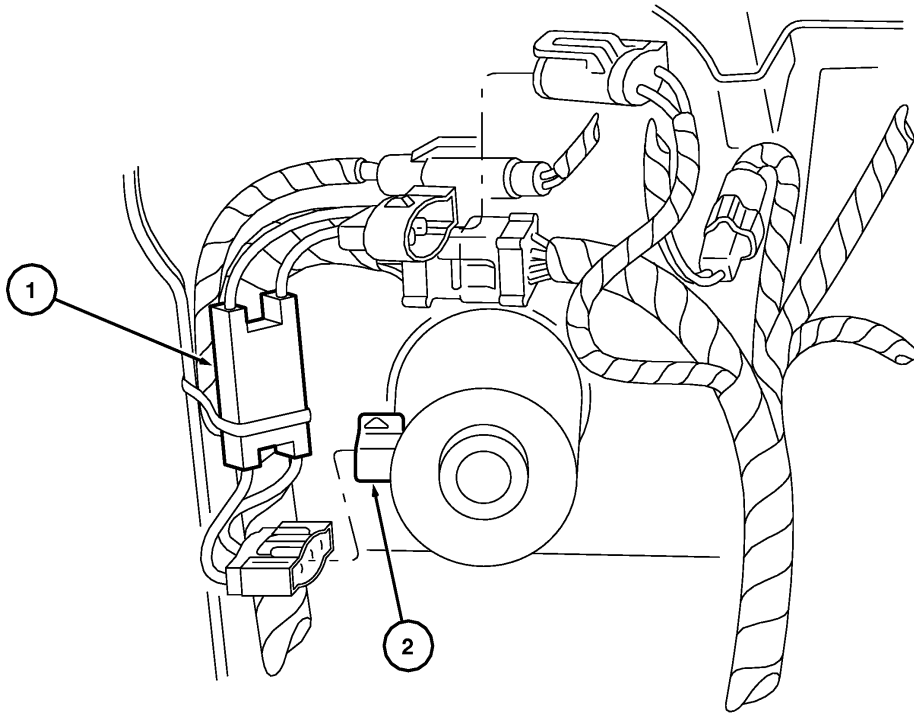

A0075889

Item	Description
1	Noise suppression filter
2	Blower motor connection

## Section 3: Electrical

- Radio Antenna Cable — This option includes a radio antenna cable that is routed from the roof panel to the luggage compartment through the left C-pillar.

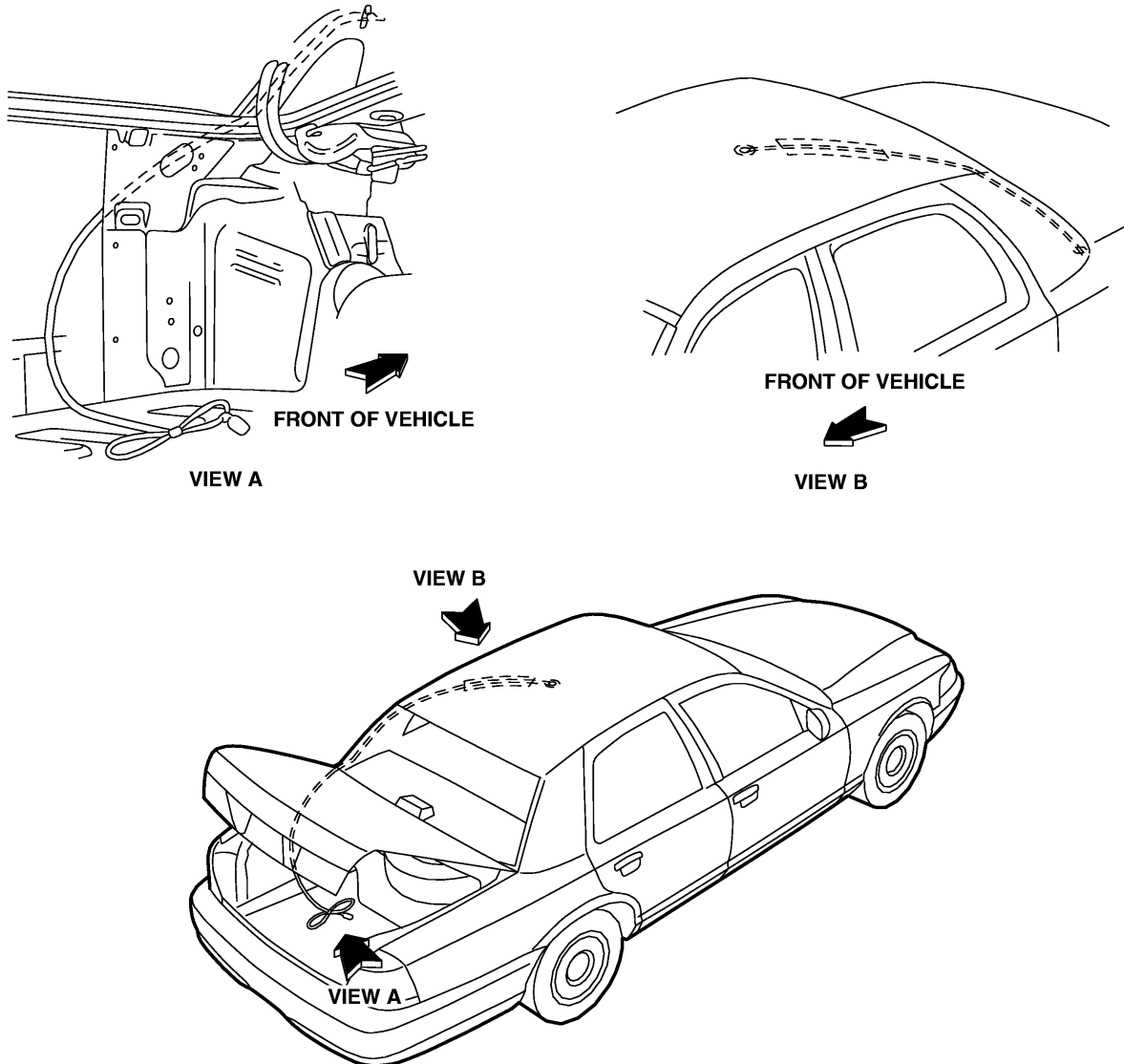

A0080792

### Regular Production Options (RPO)

#### Grille Lamps, Siren/Speaker

**Individual Option** — A wiring pre-run for grille lamps, siren/speaker is routed from the front of the vehicle to the console area. This wiring pre-run includes circuits to connect a switch panel and a siren / speaker. For wiring color code information, refer to the Crown Victoria Wiring Diagram Manual.



## Section 3: Electrical

**Police Prep Option** — On vehicles that have a Police Prep Package (65A, 68P or 65W), a wiring pre-run for grille lamps, siren and speaker is routed from the front of the vehicle to the console area. This wiring pre-run includes a flasher, flasher lamps, circuits to connect a switch panel and circuits to connect a siren / speaker. Depending on how the vehicle was ordered, the grille lamps, siren / speaker wiring pre-run may be routed from the front of the vehicle to the trunk. For wiring color code information, refer to the Ford Police Interceptor Preparation Packages Owner's Manual.

### 2-Way Radio Pre-wire

The 2-way radio pre-wire option is the addition of a T-type harness that connects between the AM/FM radio and AM/FM radio harness. This T-type harness provides blunt cut circuits that can be connected to a communications radio which will be audible through the front speakers. The AM/FM radio will then be audible only through the rear speakers. For additional Radio Pre-wire information, refer to Section 6: Reference Information.

### Package Tray-Under Decklid Lights

**Individual Option** — This pre-wire option, separate from and not combined with the Police Prep Package 65W or 65N, provides only the wiring for package tray lights and under decklid lights. For additional information, refer to the Crown Victoria Wiring Diagram Manual.

**Police Prep Option** — On vehicles that have the Police Prep Package 65W or 65N, there are 2 high intensity LED lights located on the package tray. These LED's are controlled by the switch panel located in the console area. For additional information, refer to the Ford Police Interceptor Preparation Packages Owner's Manual.

### Strobe Lights

 **CAUTION: Refer to the Ford Police Interceptor Preparation Packages Owner's Manual prior to installing stobe cables. Instructions define stobe module wiring variations and repinning may be required.**

Follow Ford Workshop Manual diagnosis for the stobe system. Strobe bulbs do not have filaments, therefore continuity checks are not conclusive.

# SECTION 4

## 2004 Police Interceptor Modifier Guide

### Contents

Section 4: Installation Considerations.....	4-1
Push Bumpers .....	4-1
Skid Plates.....	4-1
Siren and Grille Lights.....	4-1
Partition Installation Guidelines .....	4-2
Console Design and Installation.....	4-4
Restraint Control Module (RCM) .....	4-4
Air Bag Deployment Interference .....	4-4
Seat Bolts.....	4-5
Driveshaft Clearance .....	4-5
Electrical .....	4-5

## Section 4: Installation Considerations

### Push Bumpers

#### Effect On Air Bag Deployment

Different push bumper designs may each have different deformation characteristics in a crash situation that may or may not affect the deployment of air bags. Without the benefit of crash tests on vehicles equipped with push bumpers (there are a number of different styles available), it is the opinion of Ford Motor Company that installation of some push bumpers could affect the timing of the air bag deployment. Use of a push bumper that mounts solely to the vehicle's bumper should not have a significant effect upon air bag deployment.

#### Effect On Weight Distribution

The balance and weight distribution of a vehicle is carefully planned to achieve optimal stability and handling. Push bumpers can change this weight distribution by adding excessive weight to the front of the vehicle. There are many different styles of push bumpers available. Depending on the mounting and weight of the push bumper to be installed, it could have an adverse effect on the handling of a vehicle. Always verify the vehicle ride height after the addition of a push bumper. For additional information, refer to Section 1: General Information, Bumper Height Verification in this guide. Adjust the ride height if the measurements are not within specifications.

#### Airflow

The engine cooling system on a vehicle relies on proper airflow through the radiator to keep the engine at its proper operating temperature. When adding a push bumper to a vehicle, make sure this airflow is not obstructed, especially when lights and sirens are mounted on the push bumper. Reduced airflow could put additional strain on the cooling system and shorten the operational life of related components. During the installation process, keep the placement of components away from the grille area of the vehicle.

### Skid Plates

There are a few different skid plate designs and mounting locations available. When skid plates are mounted under the front of the vehicle covering the underside of the engine compartment, proper airflow that is necessary for the cooling system of the engine could be affected. As with push bumpers that obstruct the airflow entering the engine compartment, skid plates can obstruct airflow exiting the engine compartment. This obstruction may put a strain on the cooling system of the engine and shorten the operational life of related components.

### Siren and Grille Lights

The engine cooling system relies on proper airflow through the radiator to keep the engine at its proper operating temperature. When adding sirens and grille lights to a vehicle, make sure this airflow is not obstructed. Reduced airflow could put additional strain on the cooling system and shorten the operational life of related components. During the installation process, keep the placement of components away from the grille area of the vehicle.

## Section 4: Installation Considerations

### Partition Installation Guidelines

 **WARNING: THE PARTITION AND THE INSTALLATION HARDWARE OF THE PARTITION MUST NOT INTERFERE WITH THE PROPER OPERATION OF THE SAFETY BELT, SAFETY BELT RETRACTOR, SIDE IMPACT SENSOR AND THE SAFETY BELT HEIGHT ADJUSTERS. FAILURE TO FOLLOW THESE INSTRUCTIONS MAY RESULT IN PERSONAL INJURY.**

 **WARNING: INSTALLATION OF PRISONER PARTITIONS MAY INCREASE THE RISK OF INJURY TO FRONT SEAT OCCUPANTS IF THE VEHICLE IS IMPACTED FROM A HIGH SPEED REAR END COLLISION. THIS RISK SHOULD BE BALANCED BY THE LAW ENFORCEMENT AGENCY AGAINST THE RISK OF INJURY TO THE OFFICER ASSOCIATED WITH PRISONER TRANSPORTATION. FAILURE TO FOLLOW THESE INSTRUCTIONS MAY RESULT IN PERSONAL INJURY.**

### Safety Belt Retractor

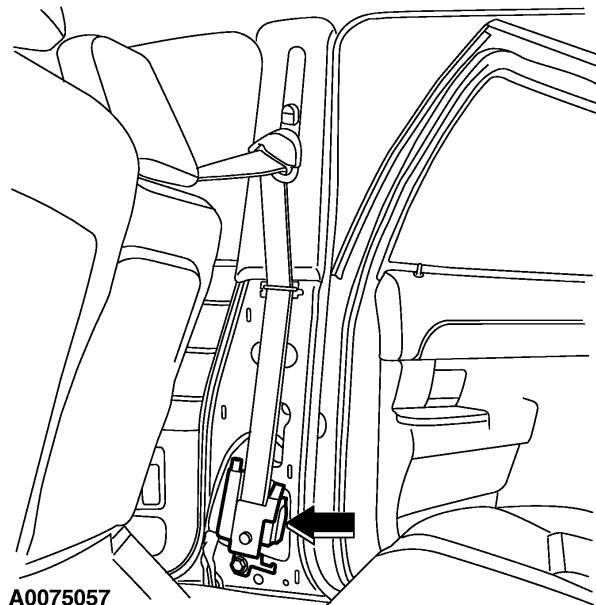

## Section 4: Installation Considerations

The seat belt retractors are located in the base of the B-pillars. The pretensioner located in the retractor is referred to as the “safety belt retractor pretensioner”. In the event of an air bag deployment, pretensioners provide improved occupant protection by rapidly removing slack from the safety belt. Removing slack from the safety belt helps to properly position the occupant and allows for maximum effectiveness of the safety belts and the air bags.

- Do not use the safety belt retractor bolts for mounting the partition.
- Do not mount any partition hardware on the inboard side of the B-pillar within the bottom 12 inches.
- Do not mount any partition hardware that will interfere with the proper sealing of the door.

Refer to the following illustration for locations that must not be used for partition mounting:

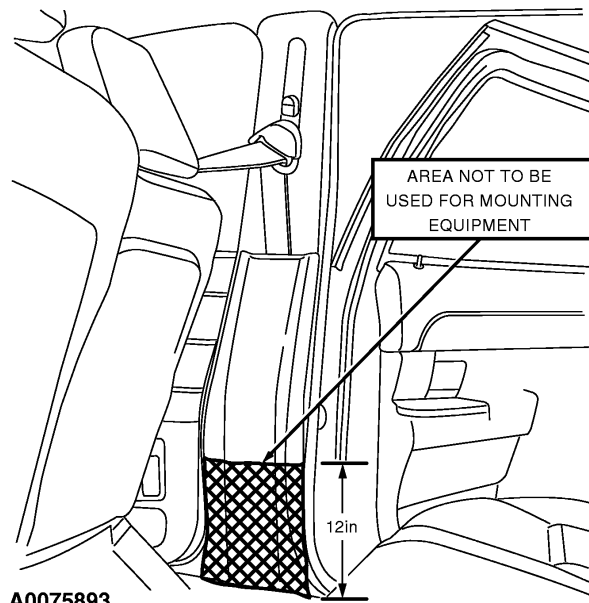

### Side Impact Sensor (if equipped)

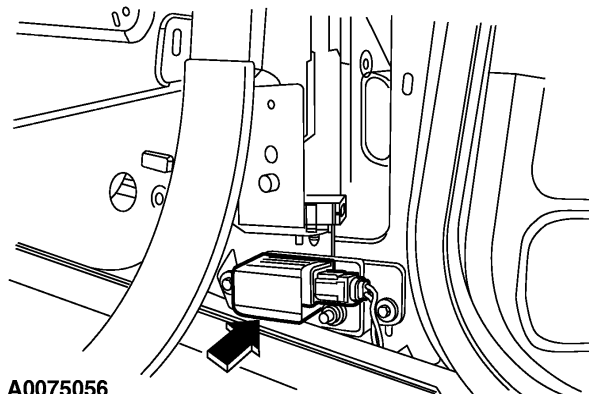

## Section 4: Installation Considerations

The side impact sensors are located in the base of the B-pillars. They are positioned below the safety belt retractors. The location and orientation are critical for the correct operation of all the impact sensors. For this reason, the attachment bolts of the impact sensors may never be used for mounting any police equipment.

Refer to the following illustration for locations that must not be used for partition mounting:

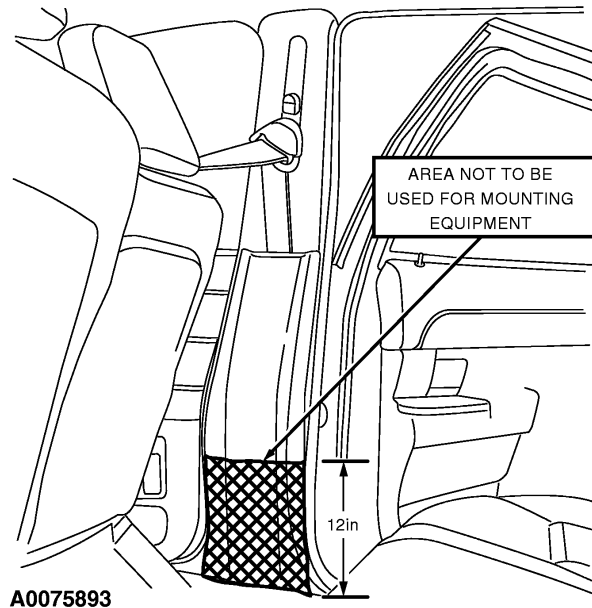

A0075893

### Console Design and Installation

### Restraint Control Module (RCM)

The restraint control module (RCM) is mounted on the center tunnel under the instrument panel. The RCM orientation is critical for proper operation of the restraint systems. Do not use the RCM mounting bolts for attachment purposes of any equipment.

### Air Bag Deployment Interference

**⚠ WARNING: DO NOT PLACE OBJECTS OR MOUNT EQUIPMENT IN FRONT OF THE AIR BAG MODULE COVER OR IN FRONT SEAT AREAS THAT MAY COME IN CONTACT WITH A DEPLOYING AIR BAG. DASH, TUNNEL OR CONSOLE MOUNTED EQUIPMENT SHOULD BE PLACED WITHIN THE SPECIFIED ZONE. FAILURE TO FOLLOW THESE INSTRUCTIONS MAY RESULT IN PERSONAL INJURY.**

## Section 4: Installation Considerations

 **WARNING: DASH, TUNNEL OR CONSOLE-MOUNTED EQUIPMENT SHOULD NOT BE PLACED OUTSIDE OF THE SPECIFIED ZONE. FAILURE TO FOLLOW THESE INSTRUCTIONS MAY RESULT IN PERSONAL INJURY.**

 **WARNING: DO NOT MOUNT EQUIPMENT BETWEEN THE SIDE OF THE FRONT SEAT AND THE DOOR TRIM THAT WOULD BLOCK DEPLOYMENT OF THE SIDE AIR BAG. FAILURE TO FOLLOW THESE INSTRUCTIONS MAY RESULT IN PERSONAL INJURY.**

Driver/passenger air bags affect the way police equipment can be mounted in police vehicles. Any surfaces that could come into contact with an air bag during deployment must not damage the air bag or alter its deployment path. Sharp edges, corners or protrusions could damage the nylon air bag material and reduce the effectiveness of the air bag. Do not mount or place any objects in the deployment path of an air bag. Air bags must be allowed to fully deploy without restriction. The deployment of air bags is not compatible with any configuration of police equipment mounting that places objects in the air bag deployment path. Equipment mounted or placed in the deployment area of an air bag will reduce the effectiveness of the air bag, damage the air bag, and potentially damage or dislodge the equipment.

Air bag deployment drawings are provided in Section 6. Consult the drawings before equipment is installed inside the passenger compartment to make sure that the mounted equipment does not interfere with air bag deployment.

### Seat Bolts

The seat bolts are not to be used as attachment points of any equipment. The added material between the seat bolt and the seat frame could have unpredictable effects on the seat bolt torque.

### Driveshaft Clearance

When installing police equipment such as a console or other equipment in the console area, it is important to consider the available clearance between the underbody and the driveshaft. Never use self-tapping screws and never use screws that are longer than necessary in the console area.

### Electrical

#### Park/Neutral Signal

In the event that the police equipment to be installed requires a park/neutral signal, there is a specific circuit that should be used. As illustrated in the Crown Victoria Wiring Diagram manual, circuit 262 (BN/PK) is routed from the Central Junction Box C1221 pin 1, to the Digital Transmission Range sensor C167 Pin 12. This is the recommended circuit segment to be spliced into when a park/neutral signal is needed. Refer to Splices and Repairs under General Guidelines in Section 2 of this Guide.

## Section 4: Installation Considerations

### Vehicle Speed Signal

 **CAUTION: Do not make electrical connections to vehicle electrical systems not specifically designed for police equipment installations.**

When adding police equipment that requires a vehicle speed signal input, such as VASCAR, use the available vehicle speed signal connection in the front power distribution box. The vehicle speed signal connection in the front power distribution box is the only recommended access to the vehicle speed signal. For additional information on the vehicle speed signal, refer to the Crown Victoria Wiring Diagrams Manual.

### Transmission Sensors

The 4R70W automatic transmission is used in all Crown Victoria applications. All Crown Victoria vehicles are equipped with the same heavy-duty transmission oil cooler. The Police Interceptor transmission is unique in the following areas:

- Torque converter
- PCM programming to produce unique transmission shift characteristics
- Longer tailshaft and extension housing to mate with the aluminum driveshaft.

Mobile communication systems may harm the operation of the vehicle, particularly if they are not properly designed for automotive use or are not properly installed. For example, when operated, such systems may cause the engine to stumble or stall and may affect 4R70W transmission operation. (Citizen band [CB] transceivers, garage door openers and other transmitters whose power output is 5 watts or less will not ordinarily affect the operation of the vehicle.)

### Battery Saver

All Crown Victoria vehicles are equipped with a battery saver feature, which is a function of the lighting control module (LCM). The battery saver will disrupt power to the interior lamps after 10 minutes, the demand lamps after 30 minutes, and the headlamps after 10 minutes. Interior lamps include the dome lamps and the instrument cluster lamps. Demand lamps include the front map lamp, glove compartment lamp, luggage compartment lamp, and engine compartment lamp. Turning the ignition switch to the RUN or ACC position will terminate the battery saver feature by disabling the interrupt timers and reinstate power to the lamps.

A reset event will set the interior lamps interrupt timer to zero. The reset events for the interior lamps interrupt timer are: turning on the interior lamps by using the dome lamp switch, opening any door (as detected by the door ajar switches).

A reset event will set the demand lamps interrupt timer to zero. The reset events for the demand lamps interrupt timer are: opening the luggage compartment door or opening any door (as detected by the door ajar switches).



# SECTION 5

## 2004 Police Interceptor Modifier Guide

### Contents

Section 5: Trunk Mounting Considerations.....	5-1
Trunk Equipment Mounting Guide .....	5-1
Rear Axle Shelf Mounting Plate.....	5-7
Trunk Pack™ and Trunk Loading.....	5-8
Trunk Weight .....	5-10

## Section 5: Trunk Mounting Considerations

### Trunk Equipment Mounting Guide

The following trunk equipment mounting templates illustrate where fasteners are not allowed, where blunt head fasteners must be used and where standard fasteners are allowed. Be aware of the following component locations when mounting equipment in the trunk:

- Fuel tank
- Fuel lines
- Brake lines
- Evaporative emissions canister
- Electronic Modules
- Wiring harnesses

Note: Refer to Section 6: Reference Information in this guide for additional illustrations showing the location of the fuel tank, fuel lines, brake lines, wiring harnesses, evaporative canister and the fuel pump shut-off switch.

Note: Trunk equipment mounting templates are for reference only. Inspection behind trunk side trim and under carriage advised for accurate component locations.

## Section 5: Trunk Mounting Considerations

### Trunk Sides

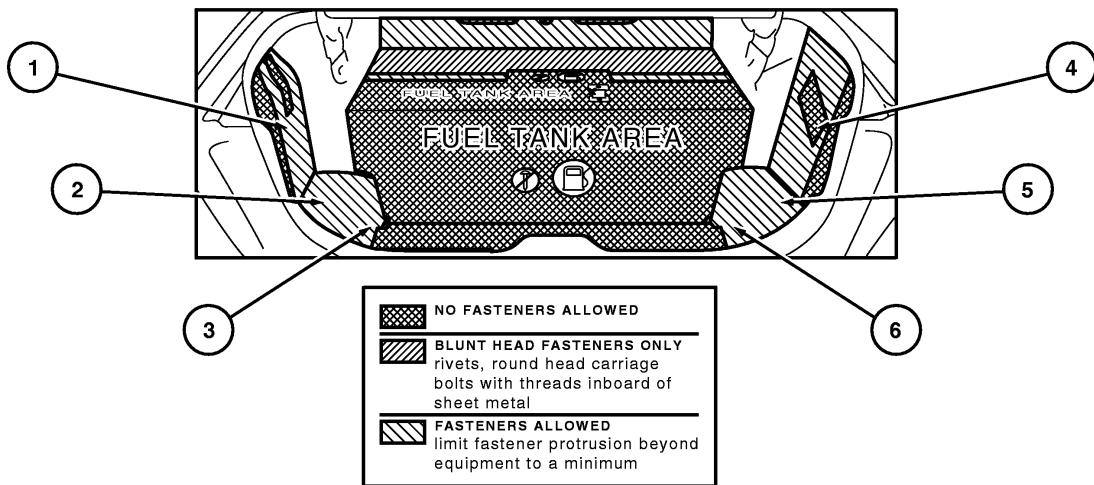
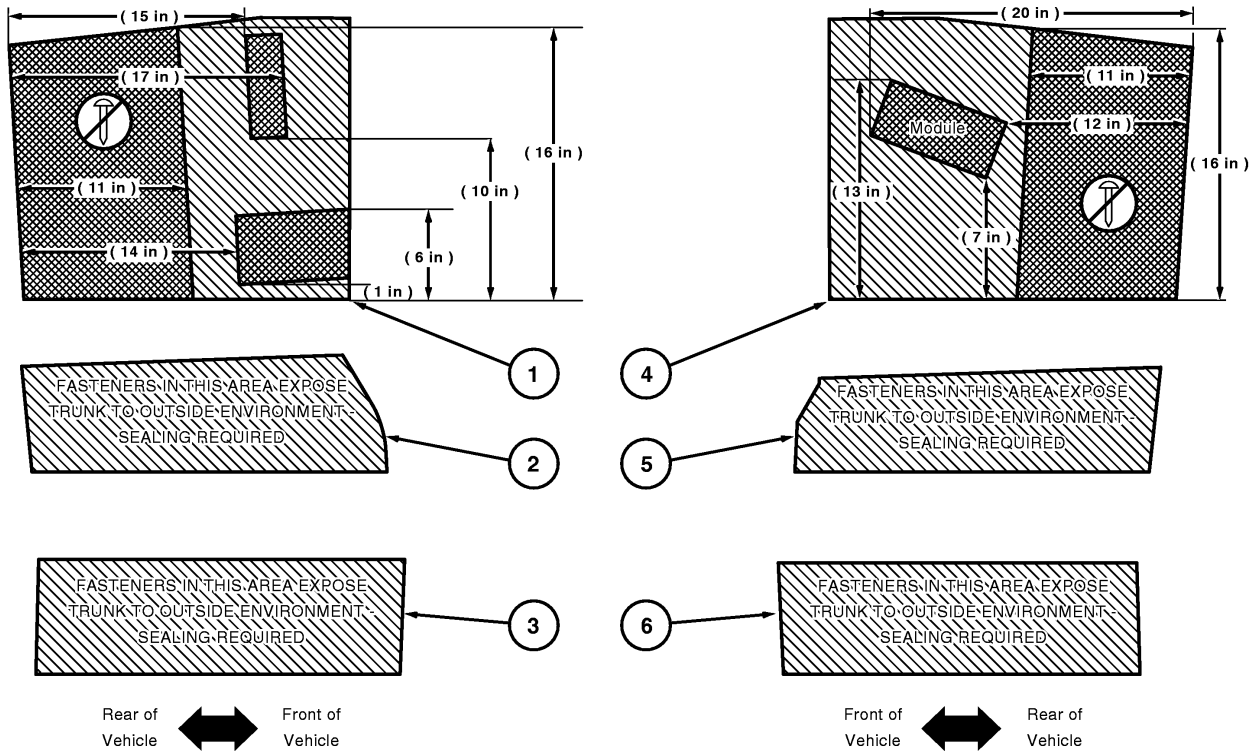

A0075395

## Section 5: Trunk Mounting Considerations

Note: For the location of the Fuel Pump Shut-off Switch, refer to Section 6: Reference Information in this guide.

### Trunk Bottom

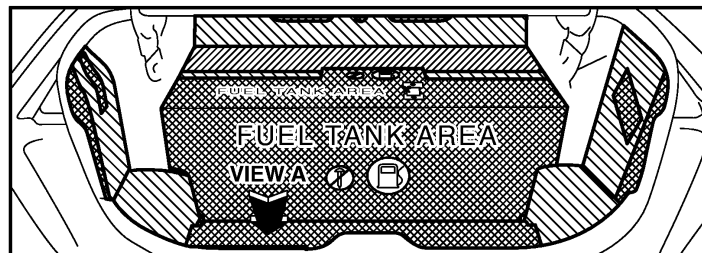
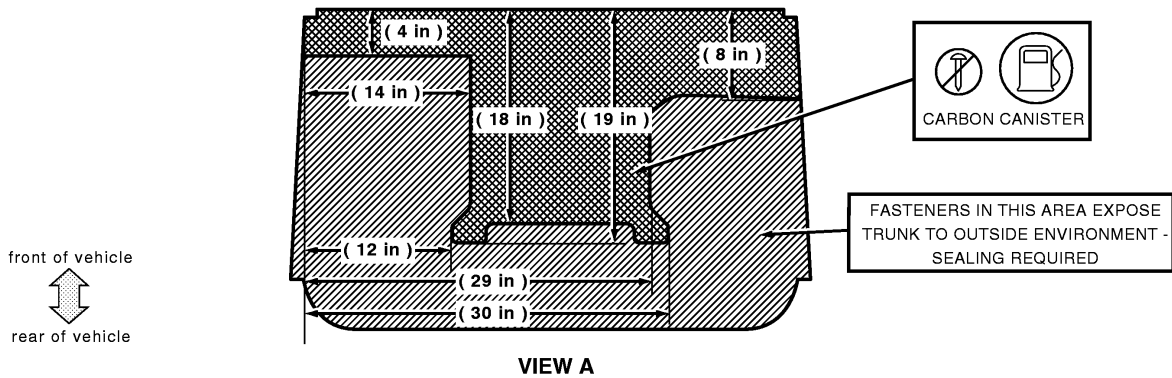

- |  |                                                                                                           |
|--|-----------------------------------------------------------------------------------------------------------|
|  | <b>NO FASTENERS ALLOWED</b>                                                                               |
|  | <b>BLUNT HEAD FASTENERS ONLY</b><br>rivets, round head carriage bolts with threads inboard of sheet metal |
|  | <b>FASTENERS ALLOWED</b><br>limit fastener protrusion beyond equipment to a minimum                       |

A0075399

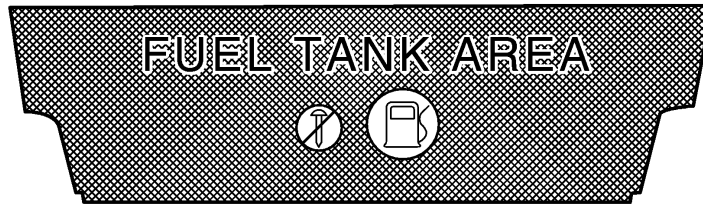

## Section 5: Trunk Mounting Considerations

Front of Deep Well

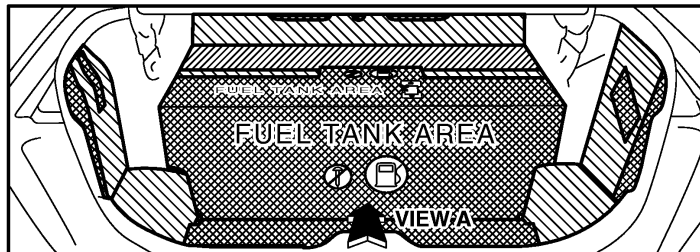

VIEW A



	<b>NO FASTENERS ALLOWED</b>
	<b>BLUNT HEAD FASTENERS ONLY</b> rivets, round head carriage bolts with threads inboard of sheet metal
	<b>FASTENERS ALLOWED</b> limit fastener protrusion beyond equipment to a minimum

A0075760

## Section 5: Trunk Mounting Considerations

### Rear Axle Shelf

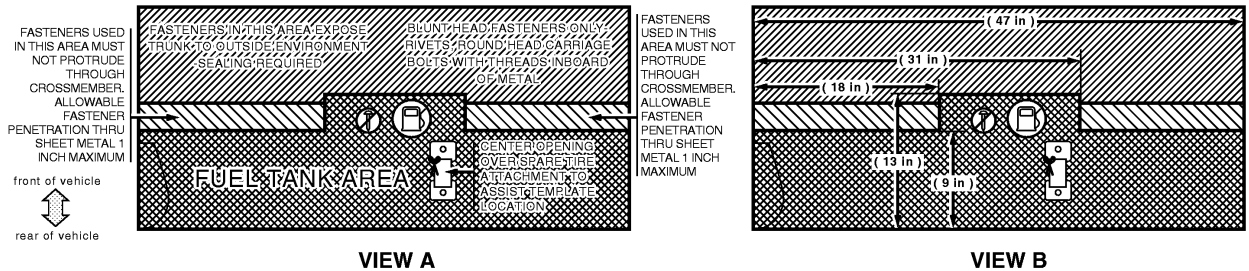

VIEW A and B

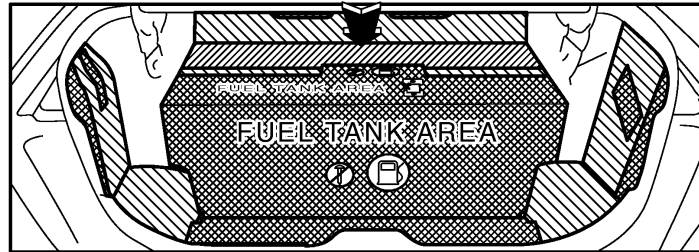





	<b>NO FASTENERS ALLOWED</b>
	<b>BLUNT HEAD FASTENERS ONLY</b> rivets, round head carriage bolts with threads inboard of sheet metal
	<b>FASTENERS ALLOWED</b> limit fastener protrusion beyond equipment to a minimum

A0075396

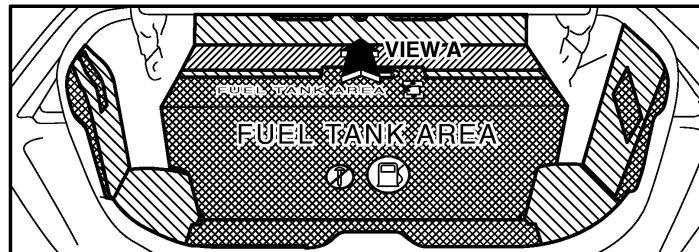
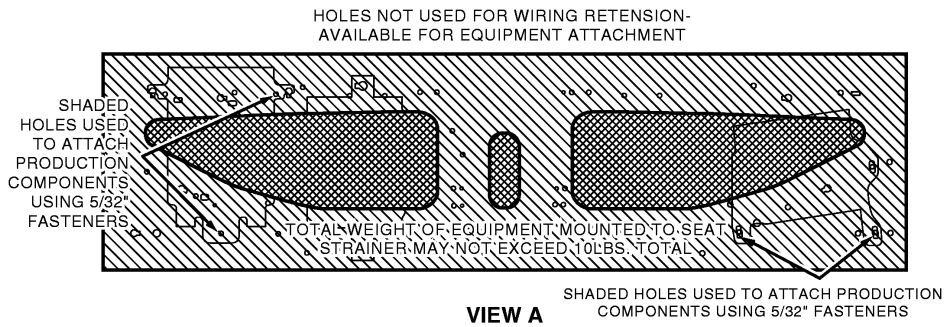
## Section 5: Trunk Mounting Considerations

### Seat Strainer



	<b>NO FASTENERS ALLOWED</b>
	<b>BLUNT HEAD FASTENERS ONLY</b> rivets, round head carriage bolts with threads inboard of sheet metal
	<b>FASTENERS ALLOWED</b> limit fastener protrusion beyond equipment to a minimum

A0075397

## Section 5: Trunk Mounting Considerations

### Package Tray

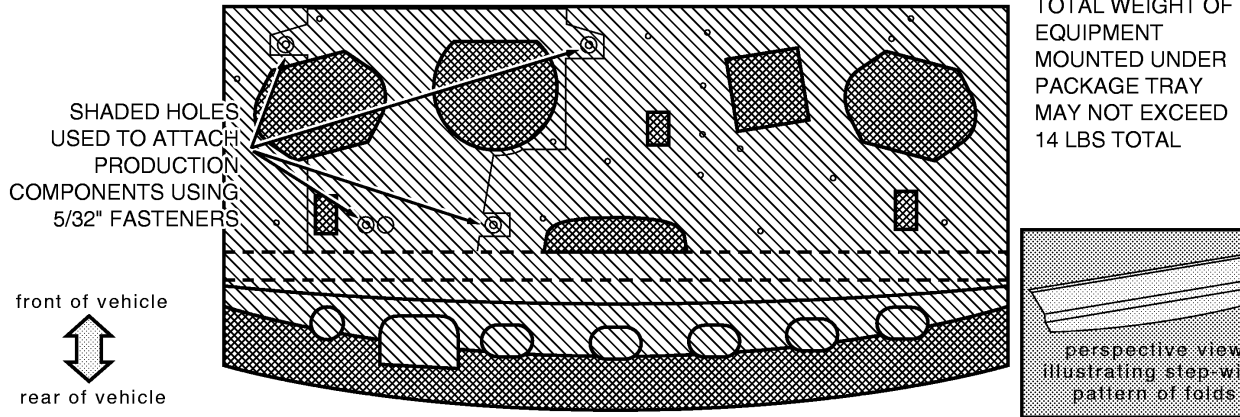

■	<b>NO FASTENERS ALLOWED</b>
▨	<b>BLUNT HEAD FASTENERS ONLY</b> rivets, round head carriage bolts with threads inboard of sheet metal
▧	<b>FASTENERS ALLOWED</b> limit fastener protrusion beyond equipment to a minimum

A0075398

### Rear Axle Shelf Mounting Plate

When mounting equipment on the rear axle shelf area of the trunk, use an intermediate plate or tray between the component to be installed and the rear axle shelf. This will provide component mounting flexibility by increasing the amount of attachment points available. For additional information, refer to the Trunk Equipment Mounting Guide that can be found on previous pages in this section and on the internet at [www.cvpi.com](http://www.cvpi.com).



## Section 5: Trunk Mounting Considerations

### Trunk Pack™ and Trunk Loading

**⚠ WARNING: FORD RECOMMENDS THAT POLICE EQUIPMENT BE BOTH SECURED AND LATERALLY ALIGNED. HARD, STIFF OR SHARP OBJECTS, ESPECIALLY WHEN NOT SECURED OR PROPERLY LOCATED, POSE A RISK TO THE FUEL TANK AND BACK SEAT OCCUPANTS. AFTER-MARKET ORGANIZERS THAT DO NOT ADEQUATELY DEFORM IN REAR-IMPACTS CAN THEMSELVES BECOME INJURY-PRODUCING OBJECTS. WHEN LOCATING, SECURING AND MOUNTING POLICE EQUIPMENT, PLEASE REVIEW THE “TRUNK EQUIPMENT MOUNTING GUIDE,” AVAILABLE ON THE WWW.CVPI.COM WEBSITE, WHICH PROVIDES RECOMMENDED FASTENER MOUNTING TYPES AND LOCATIONS.**

**FOLLOWING THE TRUNK PACKING RECOMMENDATIONS, ALSO ON THE WWW.CVPI.COM WEBSITE, IS THE MOST MEANINGFUL METHOD OF REDUCING RISK. IF YOUR DEPARTMENT PRACTICE IS INCONSISTENT WITH THE TRUNK PACKING RECOMMENDATIONS, THEN FORD SUGGESTS THAT YOU CONSIDER PURCHASING AN OPTIONAL DROP-IN TRUNK PACK™ TO FURTHER REDUCE THE RISK OF INJURY RESULTING FROM POLICE EQUIPMENT PUSHING FORWARD INTO THE BACK SEAT AND/OR FUEL TANK IN THE EVENT OF A HIGH-SPEED REAR IMPACT. THE TRUNK PACK™ PROVIDES MORE FLEXIBILITY TO OFFICERS TRANSPORTING POLICE EQUIPMENT THAN THE TRUNK PACKING RECOMMENDATIONS.**

To improve trunk packing by police agencies, Ford has made the following items available:

- Trunk Pack™ — a drop-in box with a tough plastic shell made of High Density Polyethylene (HPDE). It both aligns police equipment laterally in the trunk and utilizes a DuPont™ KEVLAR® lining on the fore side of the box to reduce the risk of police equipment penetrating into the fuel tank and/or the back seat in high speed rear impacts.
- Trunk Equipment Mounting Guide — an outline pattern with recommended fastener mounting locations in the trunk. The guide can be found on previous pages in this section and on the internet at [www.cvpi.com](http://www.cvpi.com).
- Trunk Packing Considerations — the following guidelines are offered to reduce the risk of unique police equipment items pushing through the fuel tank and/or back seat. (see our [www.cvpi.com](http://www.cvpi.com) website for more details).

A slogan has been developed to increase police agency awareness of the importance of trunk packing.

Improve police officer safety by implementing a trunk-packing process called “LOAD SAFE”.

LOAD	SAFE
Lateral	Soft
Orientation	And
And	Fixed
Direction	Equipment

## Section 5: Trunk Mounting Considerations

### Equipment Categories and Placement

 **WARNING: GASOLINE SHOULD NOT BE STORED IN THE TRUNK AT ANY TIME, REGARDLESS OF CONTAINER. FAILURE TO FOLLOW THIS INSTRUCTION MAY RESULT IN PERSONAL INJURY.**

It is recognized that a wide variety of equipment is carried in the trunks of police vehicles as noted above. This section addresses the inherent risks of various types of equipment in the event of a high-speed rear impact.

This information is divided into three categories:

- **Carrying Not Recommended** —The following items have been observed in police vehicles and should not be transported in a vehicle trunk; containers with gasoline, loose ammunition, loose flares, loose fire extinguisher(s), loose 4-point lug wrenches, loose crowbars, loose axes and other loose equipment with potential puncture capability in high-speed rear-end collisions.
- **Carry With Caution** —These items will require special packing or mounting consideration and possibly use of the Trunk Pack™ as an additional level of safety. Examples include (with proposed orientation): fire extinguisher (fixed), lug wrench 4-point (fixed, vertical), rototape measuring wheel (fixed, vertical), safety flares (lateral orientation, in a container), Stop Stick (lateral, mount on deck lid inner panel), shovel (lateral, place at rear of trunk), shotgun and rifle (lateral, store in case), baton (lateral, place at rear of trunk), electronic equipment (use Trunk Equipment Mounting Guide to determine equipment mounting locations), ammunition (container). Flares should be placed in a protective storage container (preferably soft-sided plastic). Flares with spikes attached should be laterally oriented in the trunk area.
- **Spare Tire Special Considerations:** The safest location for the spare tire, jack and lug wrench is the production location on the forward package shelf above the rear axle. If unable to mount there, the next safest location for the spare tire is mounted vertically inside the Trunk Pack™ using the J-bolt attachment device provided with the Trunk Pack™. However, if the manufacturer's location for the spare tire is changed and the area above the axle is used to mount a sliding tray, use the Trunk Equipment Mounting Guide and suitable fasteners of appropriate length to reduce the risk of fuel tank puncture. The jack and lug wrench should be stored in the rearward compartment of the Trunk Pack™.
- **Electronic Equipment:** The safest location for the electronic equipment is on the trunk forward package shelf. Some equipment can be mounted in the side shelf areas, but it must not intrude into the fuel tank area in a crash (noted in Trunk Equipment Mounting Guide). The optional Complete Police Prep Package, described in Section 1, is available to facilitate packaging of electronic components with a sliding tray for the forward package shelf and side compartments in the right and left shelf area. All equipment should be located and mounted using the "Trunk Equipment Mounting Guide" for proper positioning of fasteners. This guide can be accessed on [www.cvpi.com](http://www.cvpi.com). The sliding tray can also be used, depending on size, to properly store parts with rigid and sharp edges.

## Section 5: Trunk Mounting Considerations

— **Ammunition:** The safest place for ammunition is the forward package shelf and on the side shelves. It is recommended that a plastic storage container (see Police Prep Package (68P) - Trunk storage boxes, LH or RH box can be purchased separately from and authorized Ford dealer) be utilized and mounted using the “Trunk Mounting Equipment Guide” for proper fastener locations. It is also recommended that ammunition remain in the purchased container and be placed in a safe storage container.

• **Low Risk Items** — These items are soft in feel and pose a low risk of trunk wall, rear seat area, or fuel tank puncture. Examples are: a soft camera case, biohazard kit in plastic boxes, gloves, safety rope, tow strap, traffic cones and sleeves, rain gear, riot gear (soft), emergency blankets, bullet-resistant vests, tie straps, cloth tape, garment bags, first responder kit, Res-Q-Flo masks (placed in garment bag), fuses (plastic container), briefcases, notebooks, spray bottles, helmets, and jumper cables. It is not essential but recommended that the Trunk Pack™ be considered for organization of low risk items, especially if mixed with “Carry With Caution” items.

### Trunk Weight

The vehicle’s high-speed handling and curb height will become increasingly affected as weight is added to the trunk. The more weight that is placed in the trunk, the more it will change the ride and handling characteristics of the vehicle. Consider these factors when installing equipment and placing items in the trunk of the vehicle. For additional information, refer to Trunk Pack™ and Trunk Loading in this section.

The Vehicle Certification (VC) Label on the driver door lists a maximum load of 499Kg/1100Lb (occupants + luggage). This maximum load is a combination of 5 or 6 occupants with 91Kg/200Lb of luggage.

# SECTION 6

## 2004 Police Interceptor Modifier Guide

### Contents

Section 6: Reference Information .....	6-1
Engineering Drawings .....	6-1
Air Bag Deployment Interference .....	6-1
Fuel Lines .....	6-8
Fuel Tank — Cut View .....	6-9
Fuel Tank — Bottom View.....	6-10
Fuel Pump Shut-off Switch .....	6-11
Shields.....	6-11
Brake Lines .....	6-13
Wiring Harnesses.....	6-15
Evaporative Emissions.....	6-19
Technical Specifications .....	6-20
Power Distribution Boxes .....	6-21
Police Package Wiring Diagrams.....	6-22

## Section 6: Reference Information

### Engineering Drawings

#### Air Bag Deployment Interference

**⚠ WARNING: DO NOT PLACE OBJECTS OR MOUNT EQUIPMENT IN FRONT OF THE AIR BAG MODULE COVER OR IN FRONT SEAT AREAS THAT MAY COME IN CONTACT WITH A DEPLOYING AIR BAG. DASH, TUNNEL OR CONSOLE-MOUNTED EQUIPMENT SHOULD BE PLACED WITHIN THE SPECIFIED ZONE. FAILURE TO FOLLOW THESE INSTRUCTIONS MAY RESULT IN PERSONAL INJURY.**

**⚠ WARNING: DASH, TUNNEL OR CONSOLE-MOUNTED EQUIPMENT SHOULD NOT BE PLACED OUTSIDE OF THE SPECIFIED ZONE. FAILURE TO FOLLOW THESE INSTRUCTIONS MAY RESULT IN PERSONAL INJURY.**

**⚠ WARNING: DO NOT MOUNT EQUIPMENT BETWEEN THE SIDE OF THE FRONT SEAT TO THE DOOR TRIM THAT WOULD BLOCK DEPLOYMENT OF THE SIDE AIR BAG. FAILURE TO FOLLOW THESE INSTRUCTIONS MAY RESULT IN PERSONAL INJURY.**

Driver/passenger air bags affect the way police equipment can be mounted in police vehicles. Any surfaces that could come into contact with an air bag during deployment, must not damage the air bag or alter its deployment path. Sharp edges, corners or protrusions could damage the nylon air bag material and reduce the effectiveness of the air bag. Do not mount or place any objects in the deployment path of an air bag. Air bags must be allowed to fully deploy without restriction. The deployment of air bags is not compatible with any configuration of police equipment mounting that places objects in the air bag deployment path. Equipment mounted or placed in the deployment area of an air bag will reduce the effectiveness of the air bag, damage the air bag, and potentially damage or dislodge the equipment.

Some approximate dimensions for air bags, at full inflation, are provided in Figures 1 through 5. These dimensions are somewhat flexible and represent free form deployments without the loading of occupants. The shaded areas in Figures 6 through 8 represent available police equipment mounting zones. These zones are shown for police vehicles equipped with standard bucket seats. While bench seats are optional and still appropriate for vehicles with certain limited police equipment requirements, the standard bucket seats are recommended for vehicles that require maximum available space for police equipment mounting. The zone dimensions provided in Figures 6 through 8 are approximate and will vary with the loading of occupants in the seats.

All air bag and equipment mounting zone dimensions are approximate due to different air bag deployment characteristics.

Mount no equipment between the side of the front seat and the door trim that would block deployment of the side air bag.

## Section 6: Reference Information

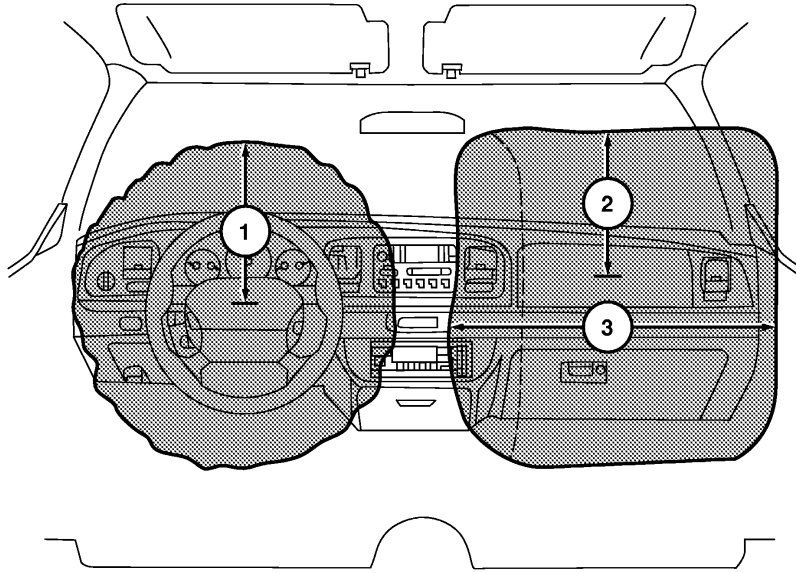

A0074658

*Figure 1.*

- (1) 240 mm (9.5 inches) from center of air bag door
- (2) 375 mm (15 inches) from center of air bag door
- (3) 750 mm (29.5 inches)

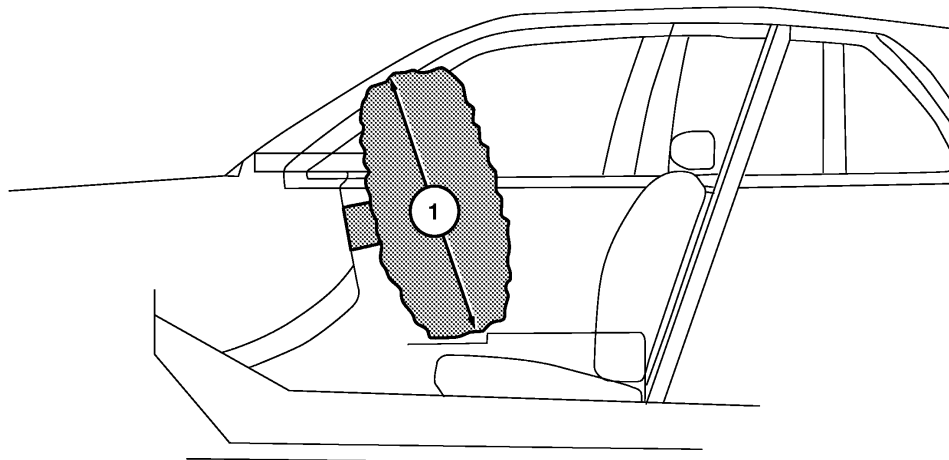

A0080796

*Figure 2.*

- (1) 660 mm (26 inches) (passenger side shown)

## Section 6: Reference Information

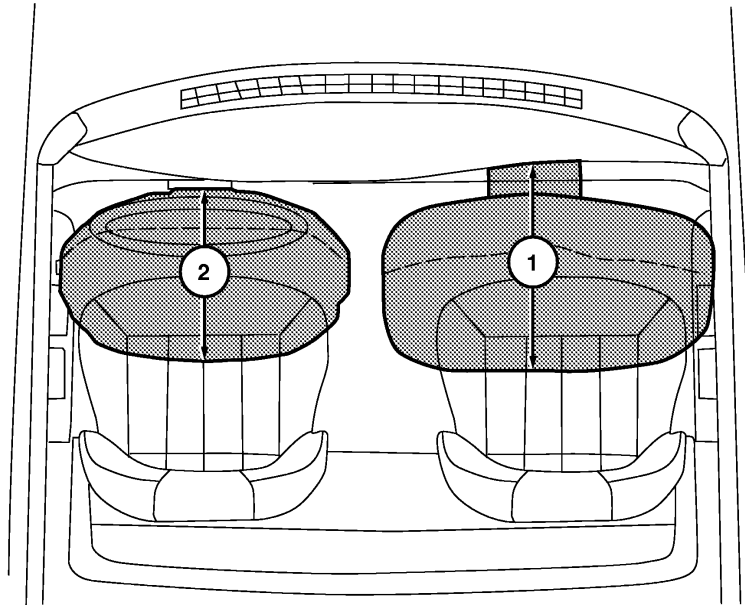

A0074660

Figure 3.

No objects should be placed between the air bags due to air bag variability.

(1) 580 mm (23 inches) front passenger

(2) 430 mm (17 inches) front driver

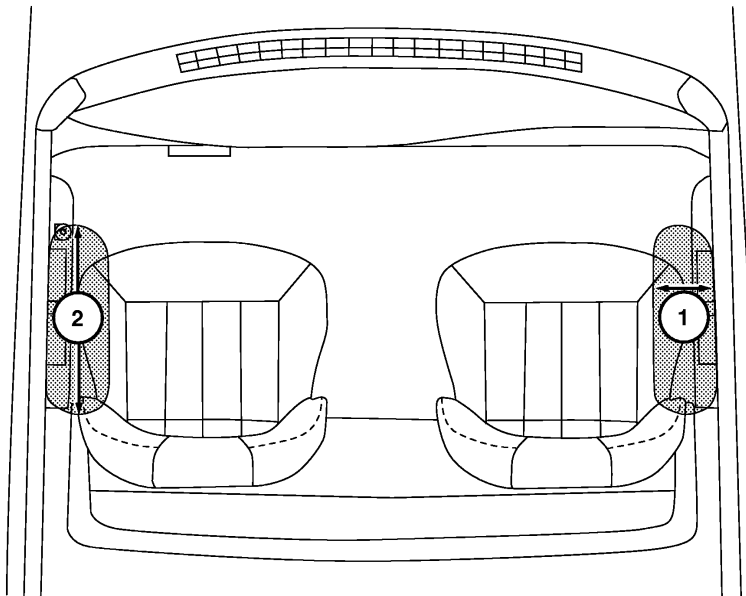

A0078523

Figure 4.

## Section 6: Reference Information

- (1) 200 mm (8 inches) from outboard side of seat
- (2) 380 mm (15 inches) forward of seat back

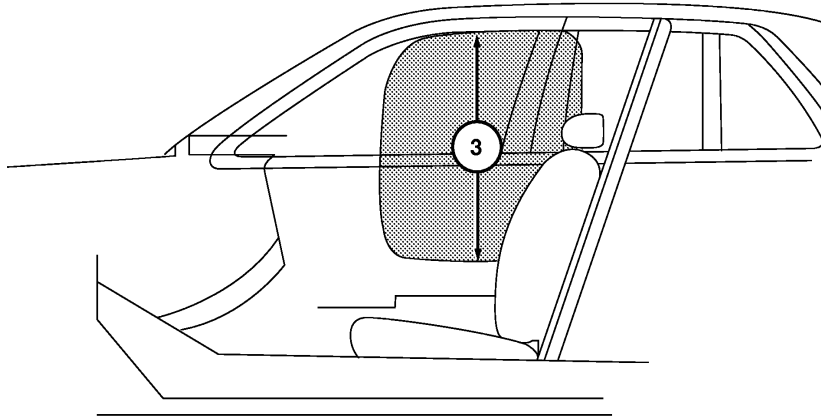

A0078524

*Figure 5.*

- (3) 700 mm (27.5 inches) up from side air bag module



## Section 6: Reference Information

Note: Figures 6 through 8 represent available police equipment mounting zones.

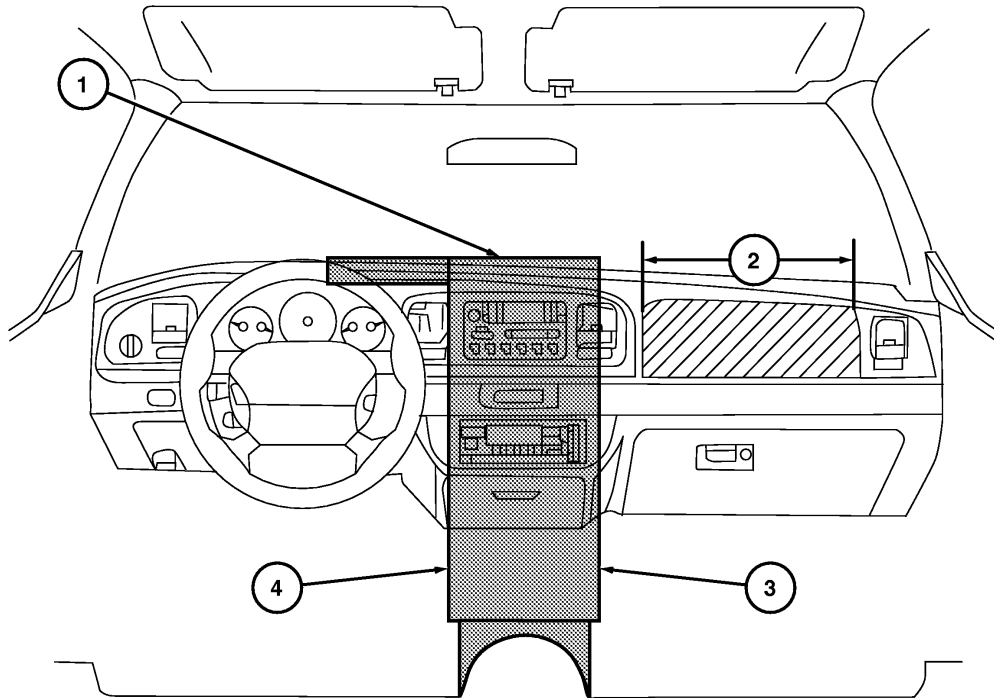

A0074662

*Figure 6.*

- (1) Area on top of instrument panel. **Equipment must not interfere with driver visibility.**
- (2) The air bag door must be kept clear for deployment of air bag.
- (3) Area in front of center console from bottom of ashtray to top of instrument panel.
- (4) 279 mm (11 inches) width horizontally centered on ashtray door.

## Section 6: Reference Information

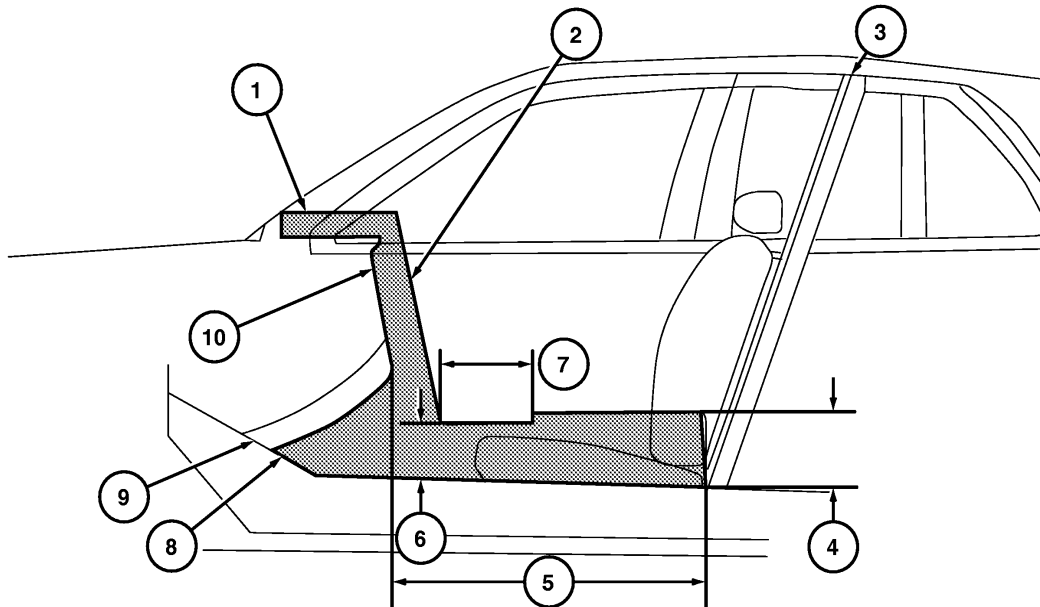

A0074663

*Figure 7.*

- (1) Area on top of instrument panel
- (2) Area in front of center console from tunnel up to instrument panel
- (3) Prisoner screen (reference only)
- (4) 254 mm (10 inches)
- (5) Area on tunnel between seats
- (6) Height: 216 mm (8.5 inches)
- (7) 305 mm (12 inches)
- (8) Area on tunnel beneath center console
- (9) Tunnel
- (10) Depth: 38 mm (1.5 inches)

## Section 6: Reference Information

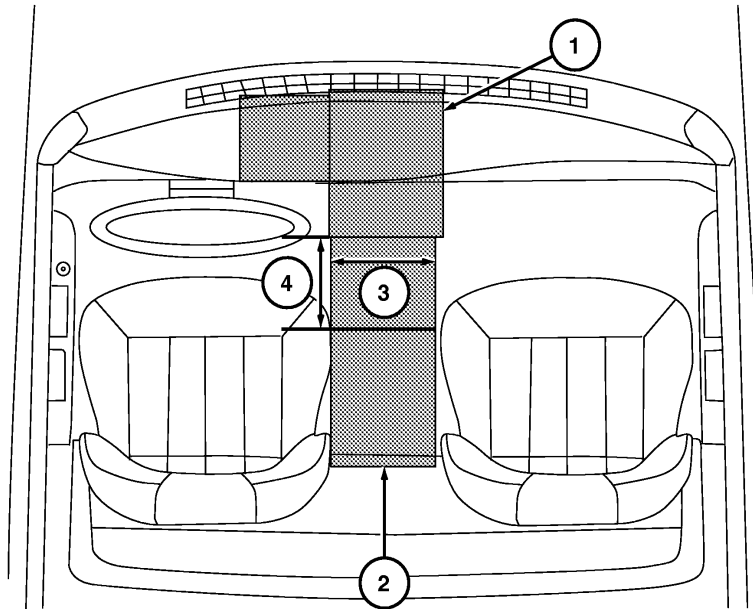

A0074664

*Figure 8.*

- (1) Area on top of instrument panel. **Equipment must not interfere with driver visibility.**
- (2) Area on tunnel between seats
- (3) 229 mm (9 inches)
- (4) 305 mm (12 inches)

## Section 6: Reference Information

### Fuel Lines

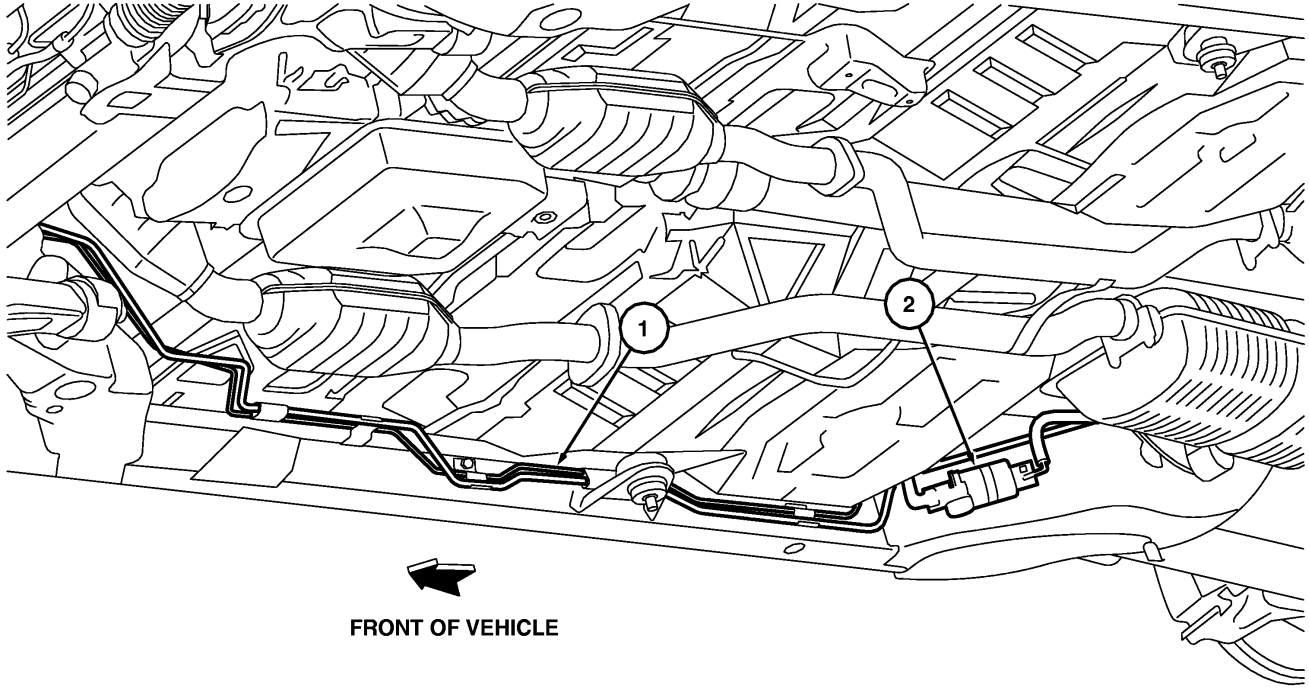

A0075894

Item	Description
1	Fuel line
2	Fuel filter

## Section 6: Reference Information

Fuel Tank — Cut View

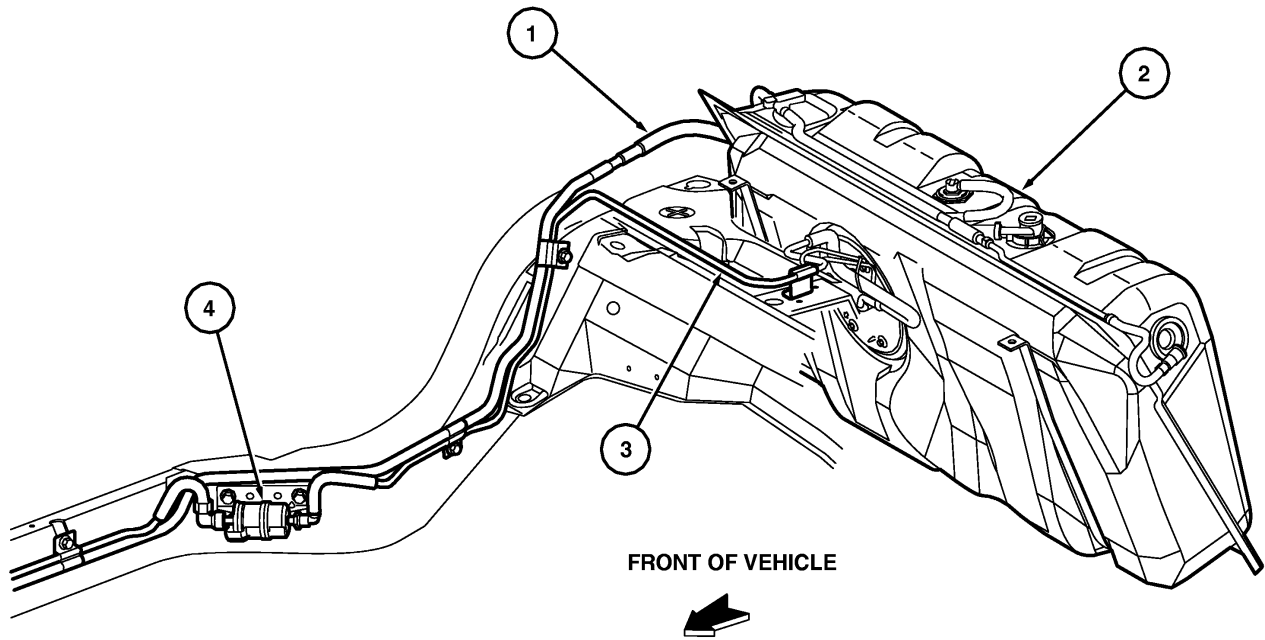

A0075895

Item	Description
1	Evaporative emissions hose
2	Fuel tank
3	Fuel line
4	Fuel filter

## Section 6: Reference Information

Fuel Tank — Bottom View

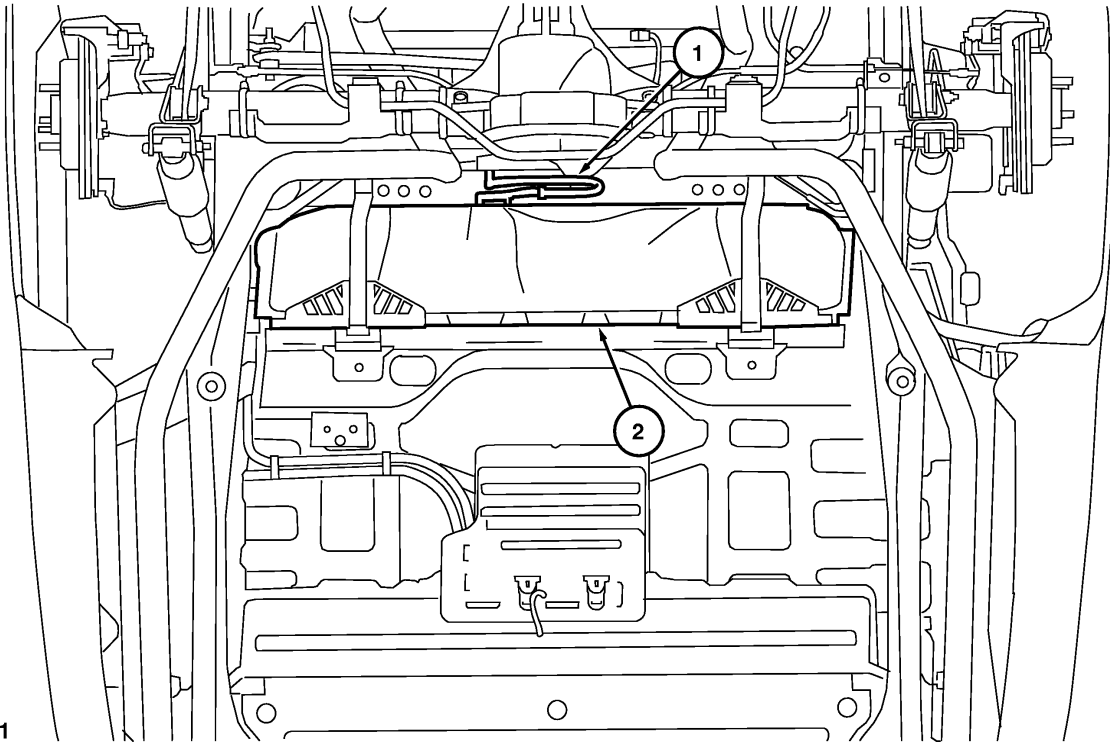

A0076591

Item	Description
1	Fuel lines
2	Fuel tank

## Section 6: Reference Information

### Fuel Pump Shut-off Switch

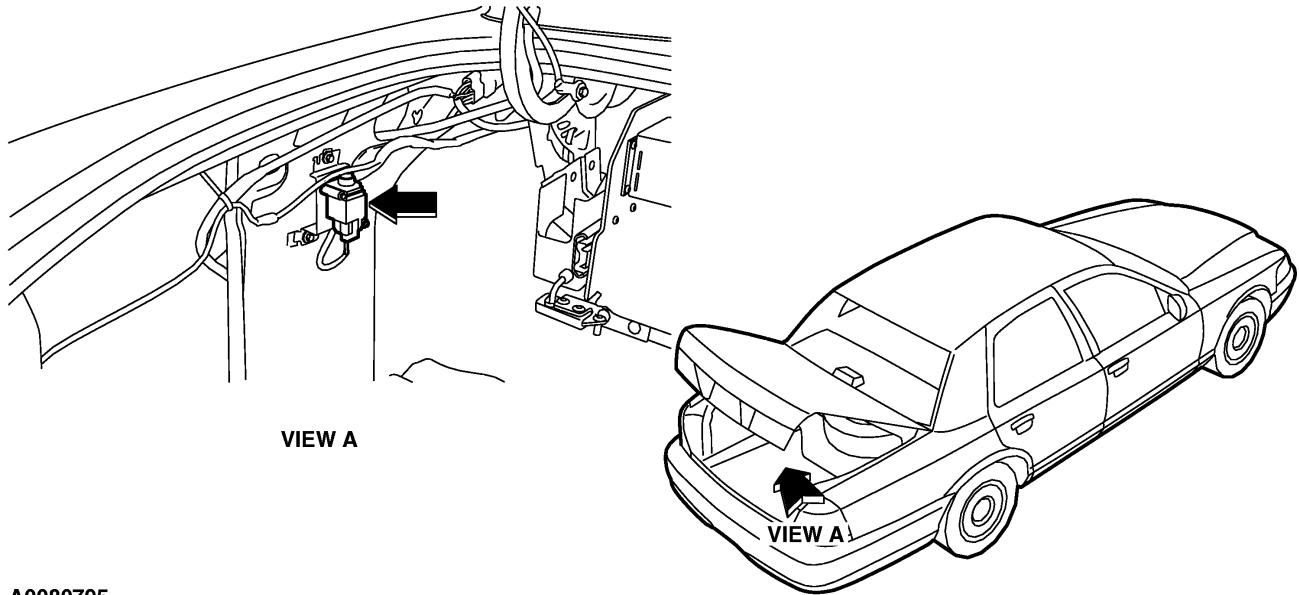

A0080795

### Shields

**⚠ WARNING: THE UNDERBODY SHIELDS THAT ARE LOCATED ON THE REAR AXLE AND FUEL TANK STRAPS MUST NOT BE REMOVED OR ALTERED IN ANY WAY. THESE SHIELDS HELP PROTECT THE FUEL TANK. FAILURE TO FOLLOW THESE INSTRUCTIONS MAY RESULT IN PERSONAL INJURY.**

Shields are installed to help protect the fuel tank from being punctured by chassis components in the event of a high speed rear end collision. These shields consist of:

- Two (2) rear axle shields
- One (1) differential cover shield
- Two (2) fuel tank strap shields
- Two (2) foam pads onto the evaporative emissions canister
- Replacement evaporative emissions canister retainer bolts and J-clips (located along the front edge of the canister) with three (3) rivets

## Section 6: Reference Information

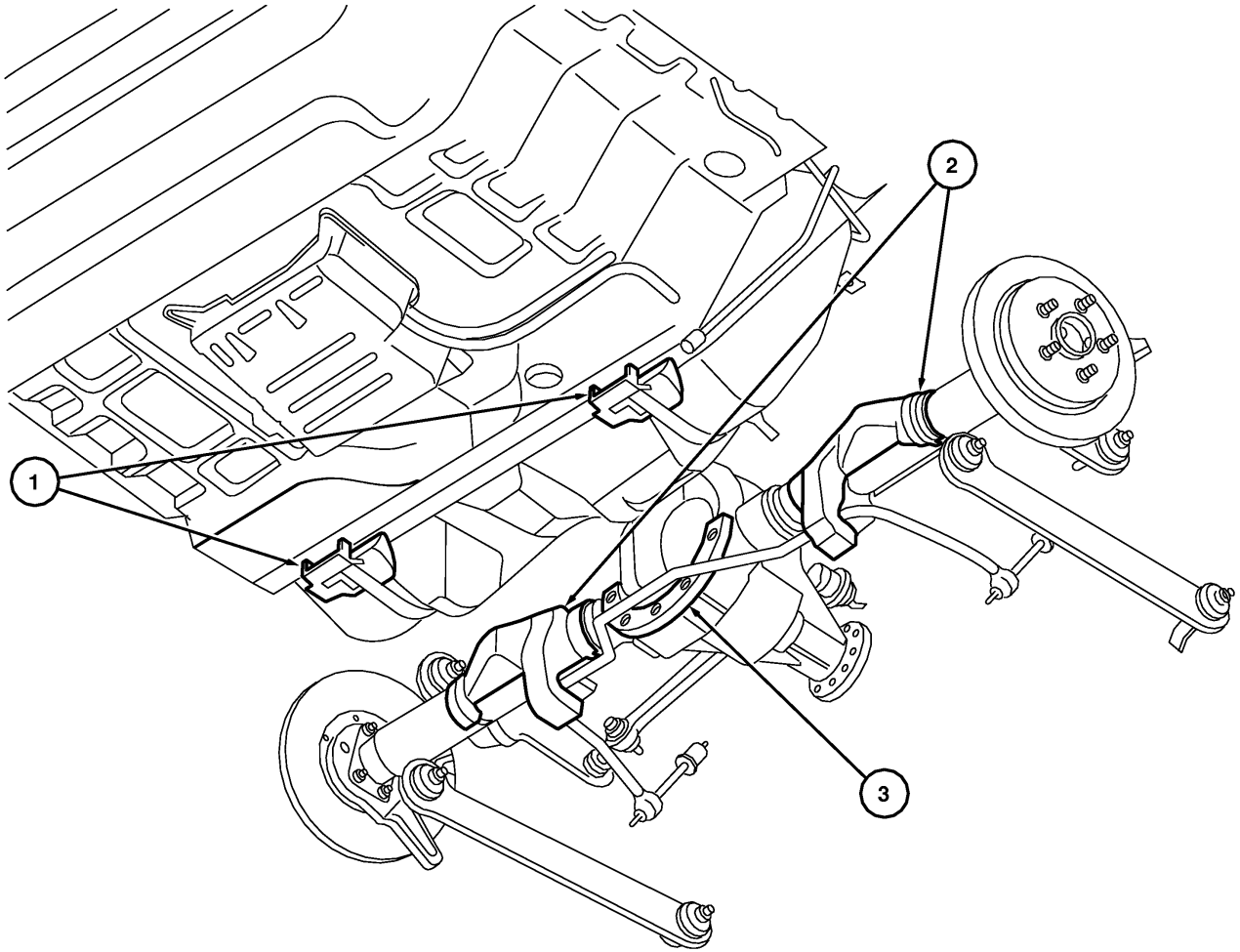

A0075891

Item	Description
1	Fuel tank strap shield
2	Rear axle shield
3	Differential cover shield



## Section 6: Reference Information

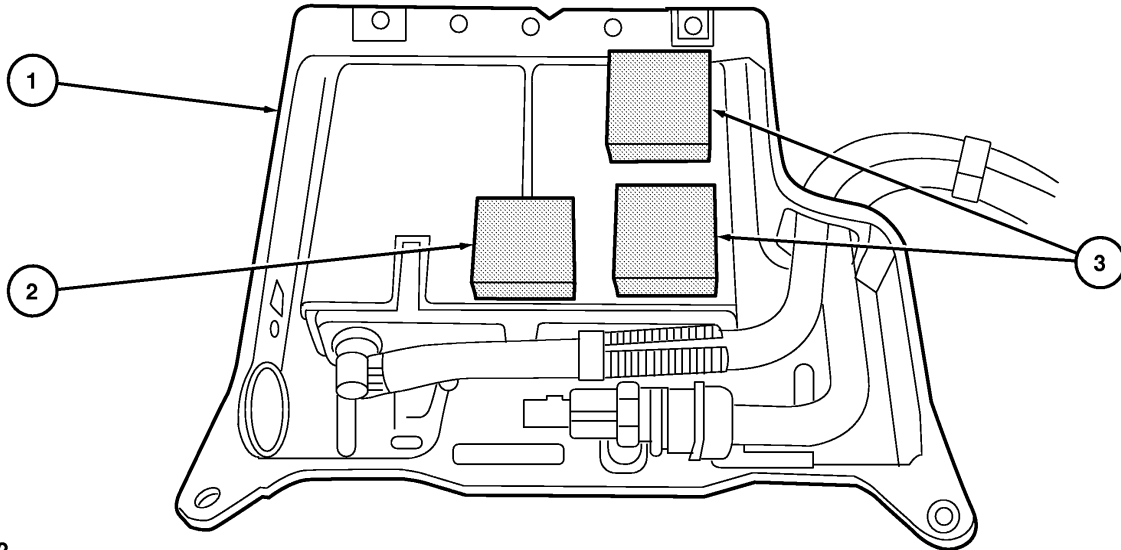

A0075892

Item	Description
1	Evaporative emissions canister
2	Existing foam pad
3	Two (2) additional foam pads (included in Optional Upgrade Kit)

### Brake Lines

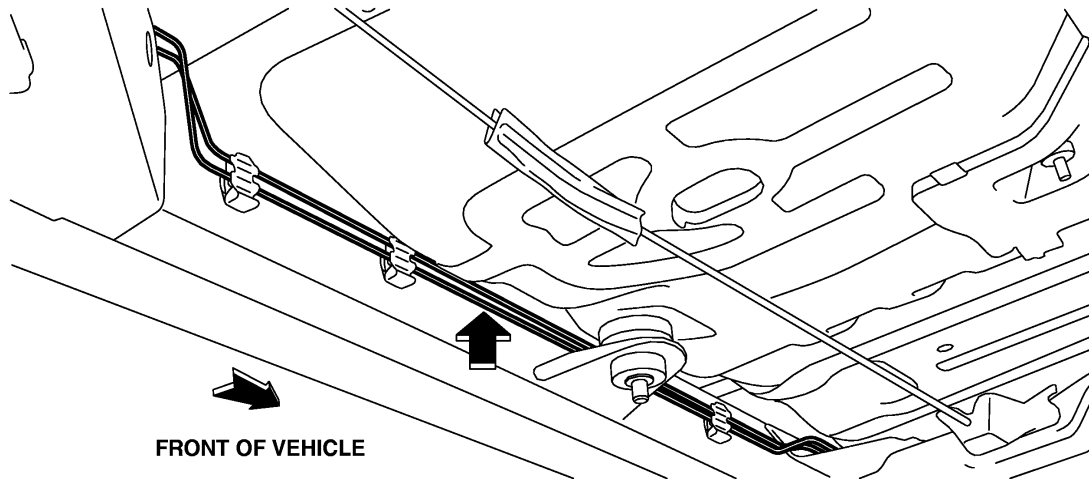

A0080652

## Section 6: Reference Information

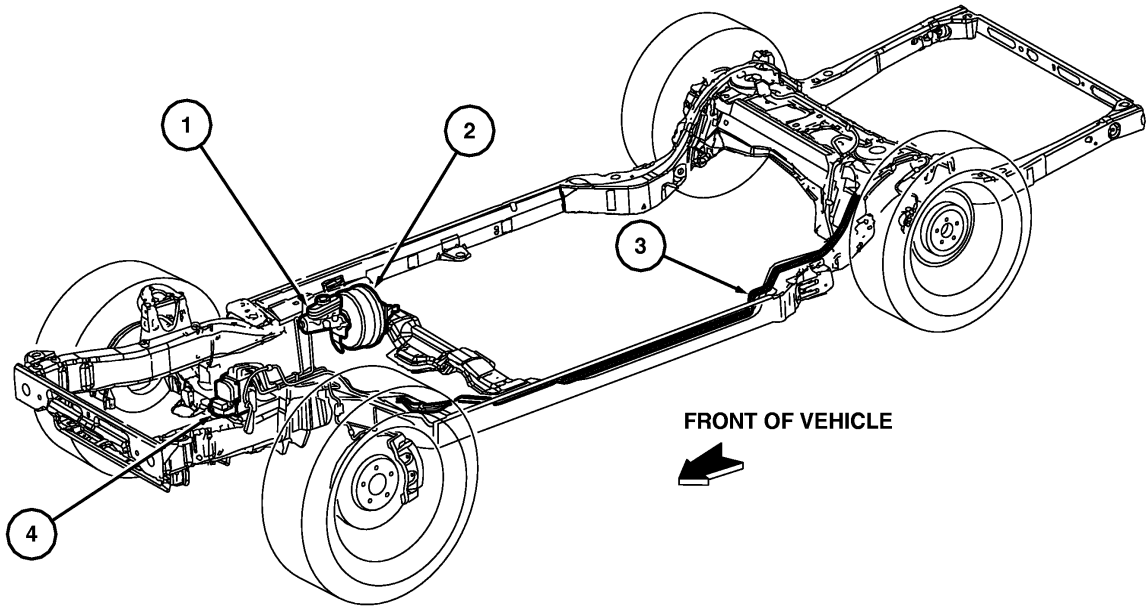

A0075896

Item	Description
1	Master cylinder
2	Brake booster
3	Brake lines
4	Brake control module

## Section 6: Reference Information

### Wiring Harnesses

Restraint control module (RCM) and RCM harness located on the driver side floor.

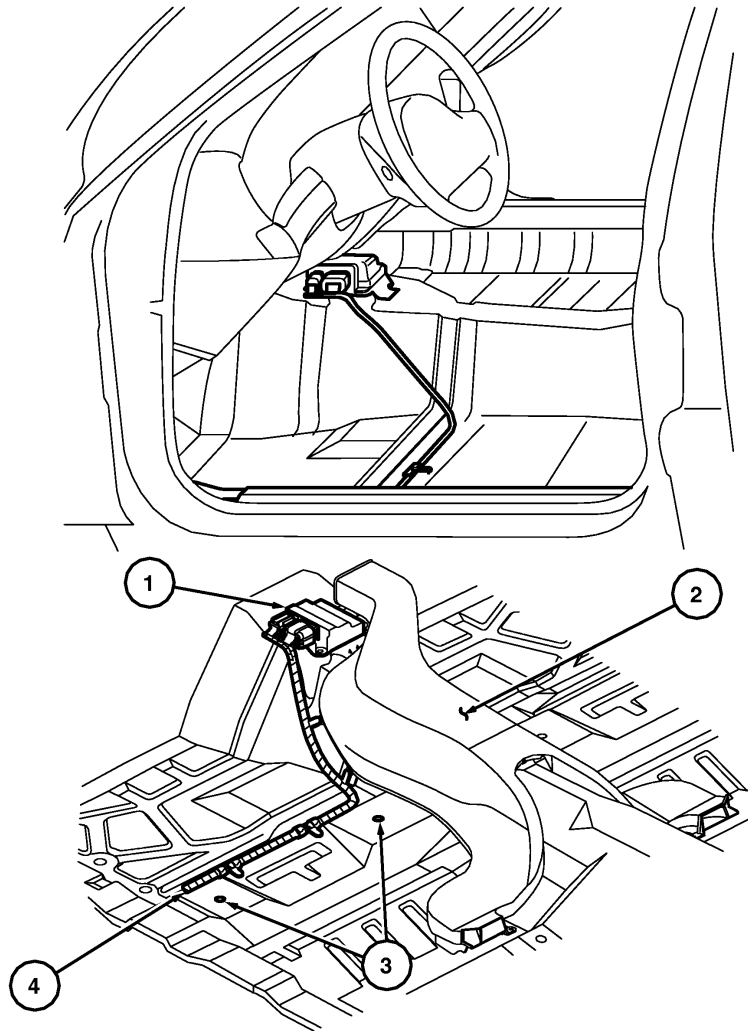

A0080653

- (1) RCM
- (2) Heating duct
- (3) Driver seat mounting holes
- (4) RCM wire harness

## Section 6: Reference Information

Segment of body harness located on passenger side kick panel and floor.

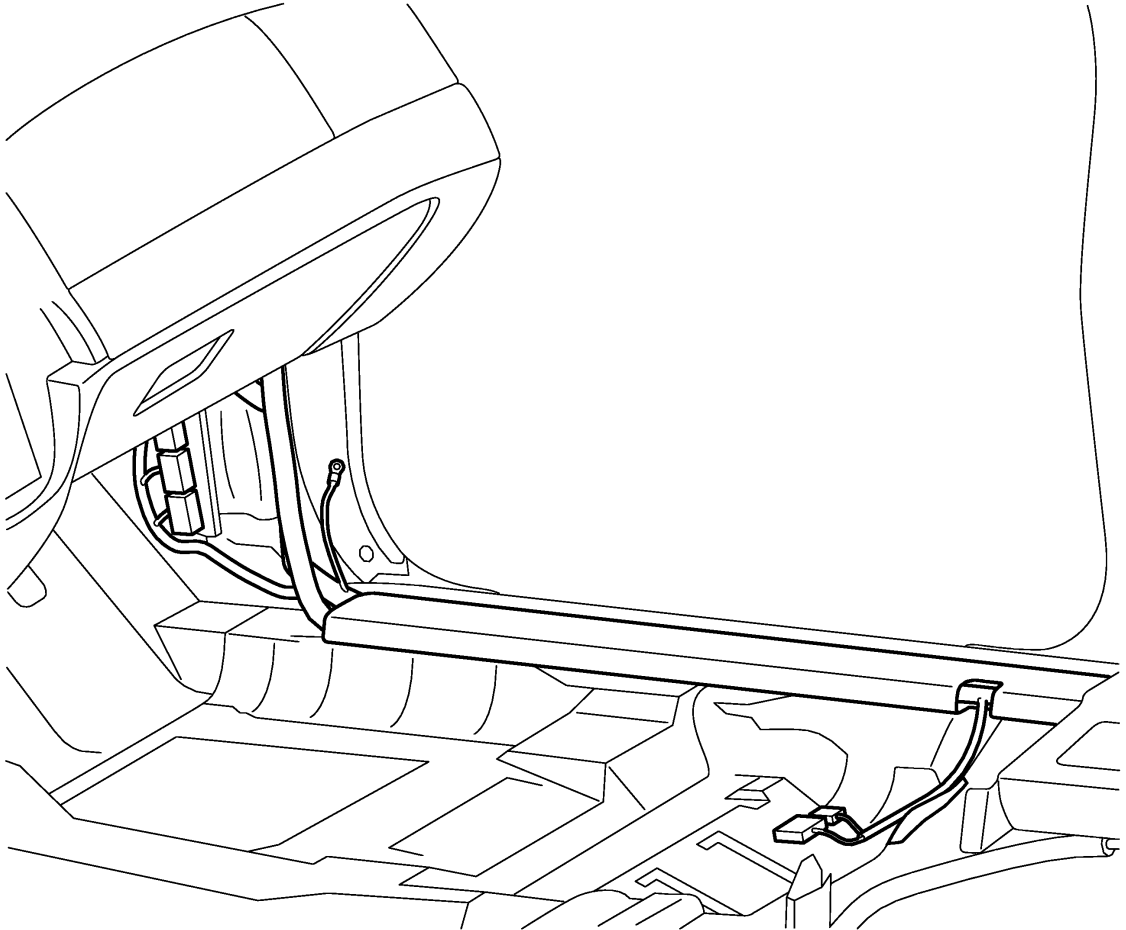

A0077007

## Section 6: Reference Information

Segment of body harness located on rear seat strainer, package tray and passenger side C-pillar.

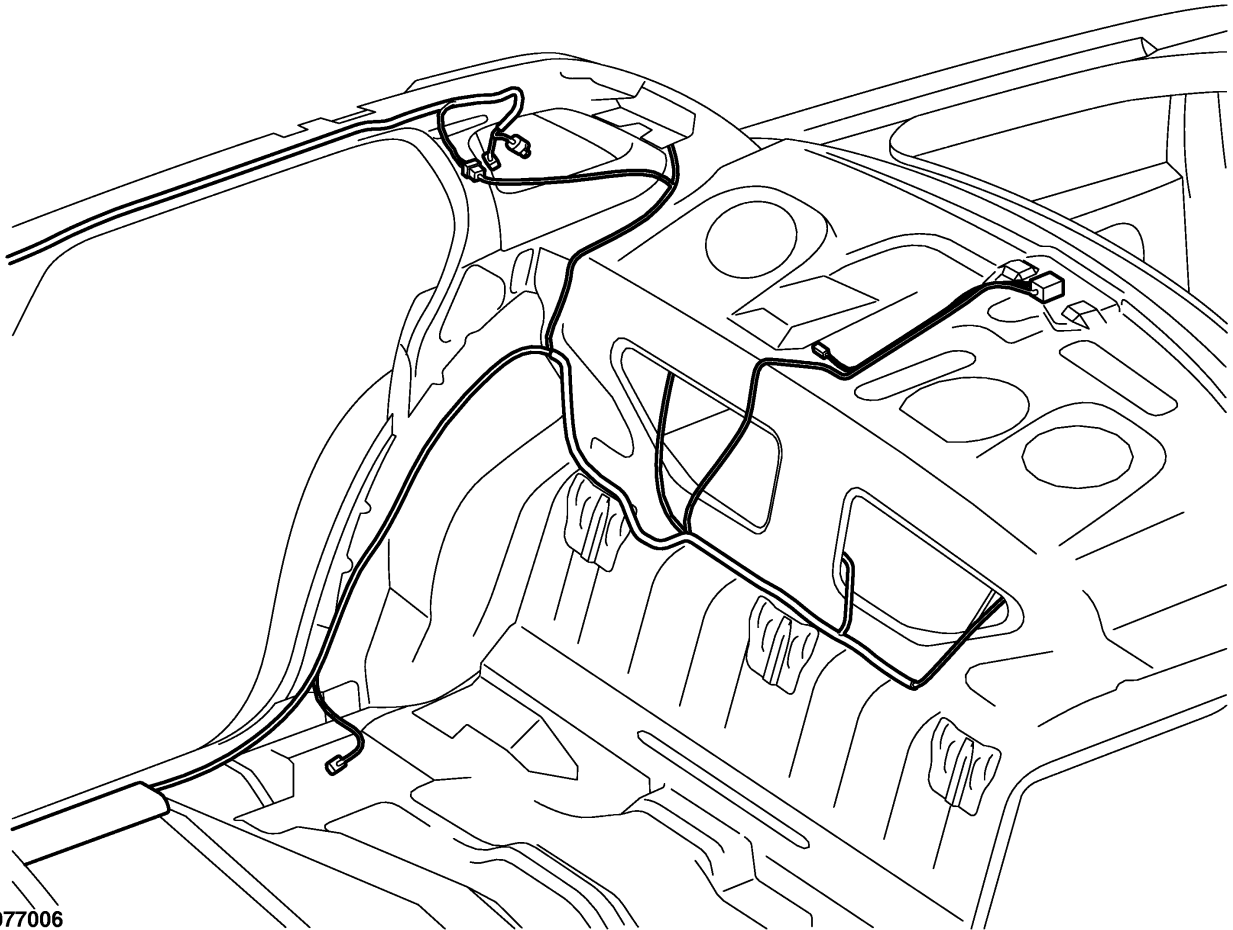

A0077006

## Section 6: Reference Information

Segment of body harness located near driver side rear door seal.

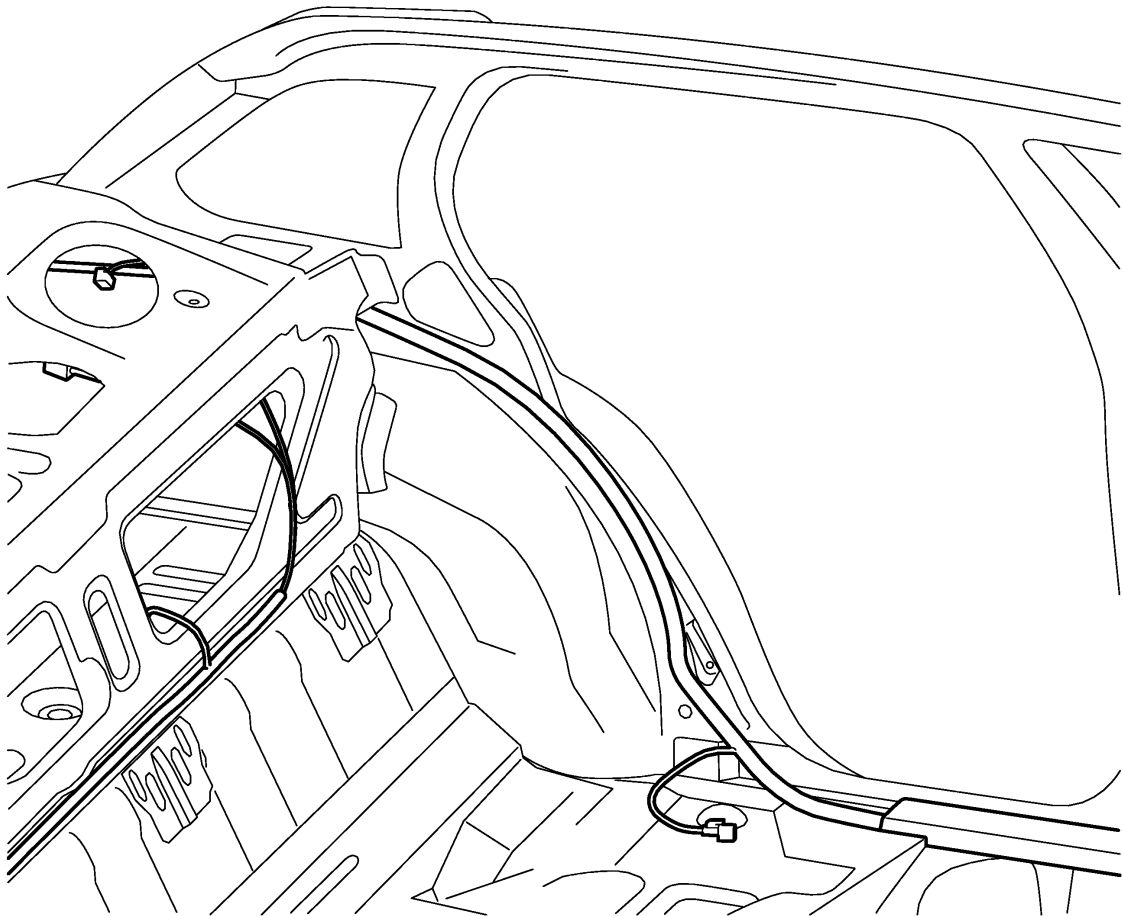

A0077009

## Section 6: Reference Information

### Evaporative Emissions

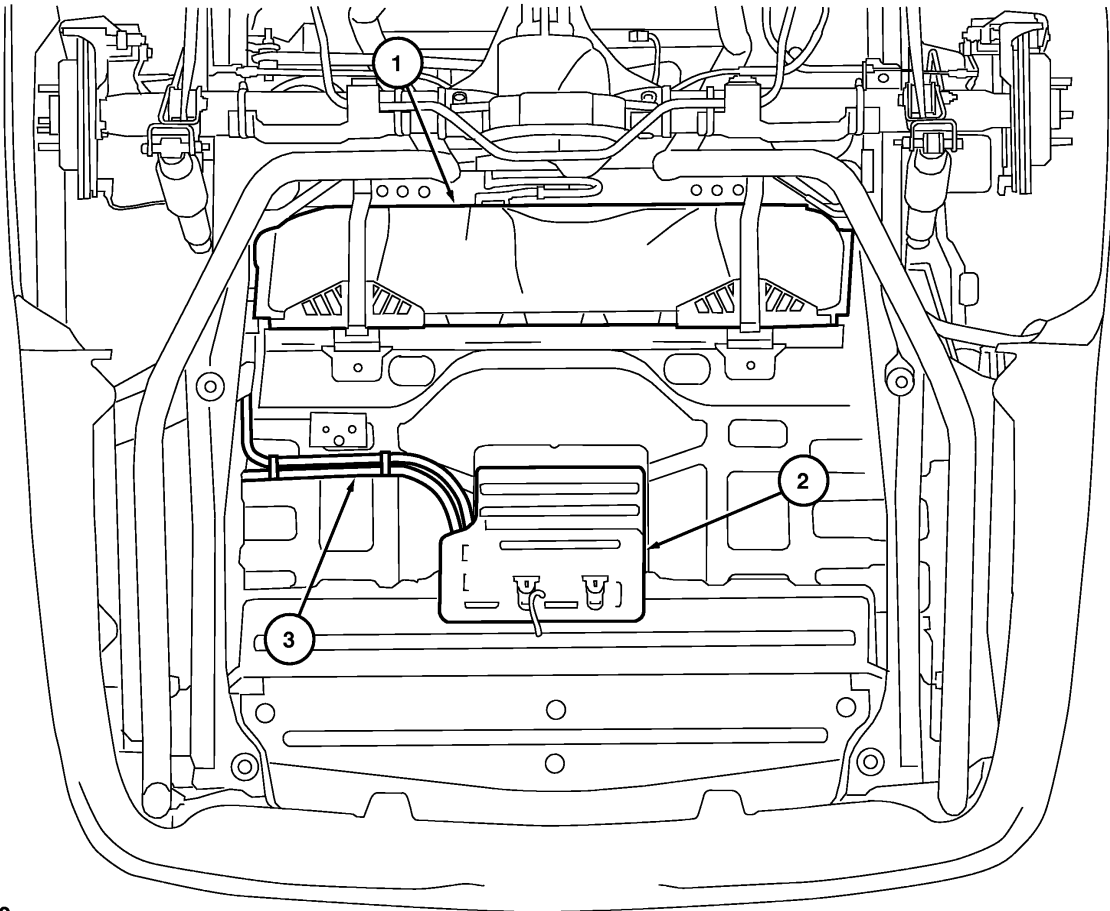

A0076592

Item	Description
1	Fuel tank
2	Evaporative emissions canister
3	Evaporative emissions hoses

## Section 6: Reference Information

### Technical Specifications

Item	Specification	Specification
Make: Ford	Model: Police Interceptor	Sales Code: P71
Engine Displacement	Cubic Inches: 281	Liters: 4.6
Fuel System	Sequential Port Fuel Injection	
Exhaust	Dual	
Horsepower (SAENET)	250 @ 5000 RPM	
Generator	200 amp	
Torque	297 ft. lbs. @ 4000 RPM	
Battery	750 cca	
Compression Ratio	9.4:1	
Transmission	Model: 4R70W	Type: 4-speed electronic automatic with lockup torque converter and overdrive.
Axle Ratio	3.27	
Steering	Power Rack and Pinion, variable ratio	
Turning circle (curb to curb)	40.3 feet	
Tire Size, Load & Speed Rating	P225/60R16 Goodyear Eagle RS-A Plus	
Suspension Type (Front)	Independent SLA with ball joint & coil spring	
Suspension Type (Rear)	4 bar link with Watts Linkage	
Ground Clearance, Minimum	6.0 inches	Location: Transmission
Brake System	Power, dual front piston, single rear piston, 4 circuit and ABS	
Brakes, Front	Type: Vented disc	Swept Area: 273 sq. in.
Brakes, Rear	Type: Vented disc	Swept Area: 176 sq. in.
Fuel Capacity	Gallons: 19.0	Liters: 71.9
General Measurements	Wheelbase: 114.7 in.	Length: 212.0 in.
General Measurements	Test Weight: 4155 lbs.	Height: 58.5 in.
Head Room	Front: 39.4 in.	Rear: 38.0 in.
Leg Room	Front: 42.5 in.	Rear: 39.6 in.
Shoulder Room	Front: 60.8 in.	Rear: 60.3 in.
Hip Room	Front: 57.1 in.	Rear: 59.0 in.
Interior Volume	Front: 58.2 cu. ft./ Rear: 51.1 cu. ft.	Combined: 109.3 cu. ft.
Interior Volume	Trunk: 20.6 cu. ft.	
EPA Mileage Est. (MPG)	City: 16/Highway: 21	Combined: 18



## Section 6: Reference Information

### Power Distribution Boxes

#### Police auxiliary junction box, front

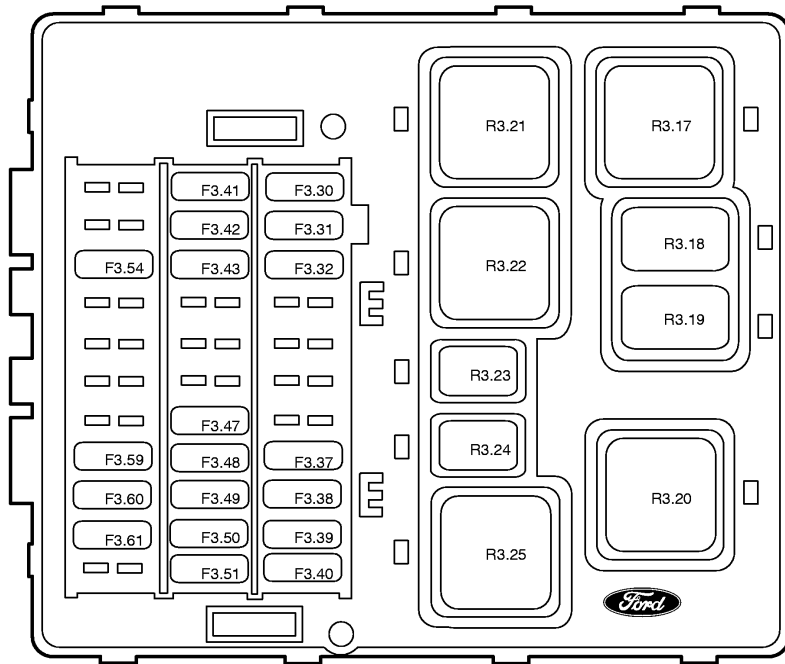

A0080793

Maxi-fuse	Amps	Circuits Protected
F3.30	15	Police Accessory
F3.31	10	Police Accessory
F3.32	20	Police Accessory
F3.33		not used
F3.34		not used
F3.35		not used
F3.36		not used
F3.37	15	Police Accessory
F3.38	10	Police Accessory
F3.39	10	Police Accessory
F3.40	10	Police Accessory
F3.41	20	R3.17 Relay
F3.42	10	Police Accessory
F3.43	15	Police Accessory
F3.44		not used
F3.45		not used

(Continued)

## Section 6: Reference Information

Maxi-fuse	Amps	Circuits Protected
F3.46		not used
F3.47	20	R3.20 Relay
F3.48	15	Police Accessory
F3.49	10	Hazard In
F3.50	7.5	Start
F3.51	7.5	Battery Saver
F3.52		not used
F3.53		not used
F3.54	20	R3.21 Relay
F3.55		not used
F3.56		not used
F3.57		not used
F3.58		not used
F3.59	7.5	Vehicle Speed (VSO)
F3.60	7.5	Delayed ACC
F3.61	7.5	Engine Off Signal
F3.62		not used

### Police Package Wiring Diagrams

#### 2004 Crown Victoria/Grand Marquis Wiring Diagram Excerpts

The following pages are from sections of the 2004 Crown Victoria/Grand Marquis Wiring Diagrams.

#### Ordering Information

To obtain information about ordering complete copies of Ford or Lincoln/Mercury publications, call 1-800-782-4356.

Available publications include Workshop Manuals, Wiring Diagrams, PC/ED Manuals and Owner Guides.

In addition, a publications order form can be obtained by writing to:

Ford Publications  
 C/O Helm Inc.  
 PO Box 07150  
 Detroit, MI 48207

## Section 6: Reference Information

**96-1 Police Option**

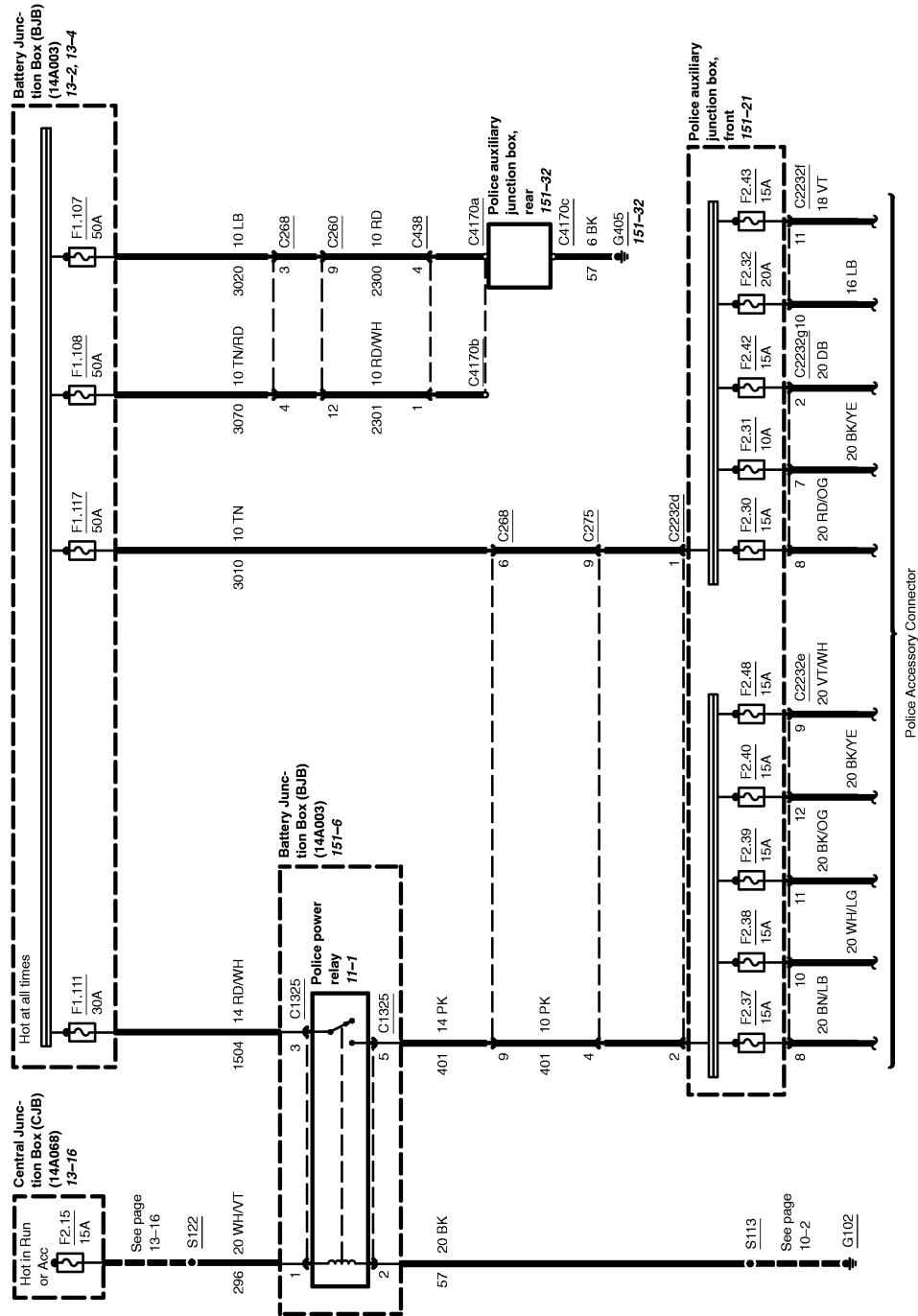

Crown Victoria/Grand Marquis '04

A0091620

# Section 6: Reference Information

Police Option 96-2

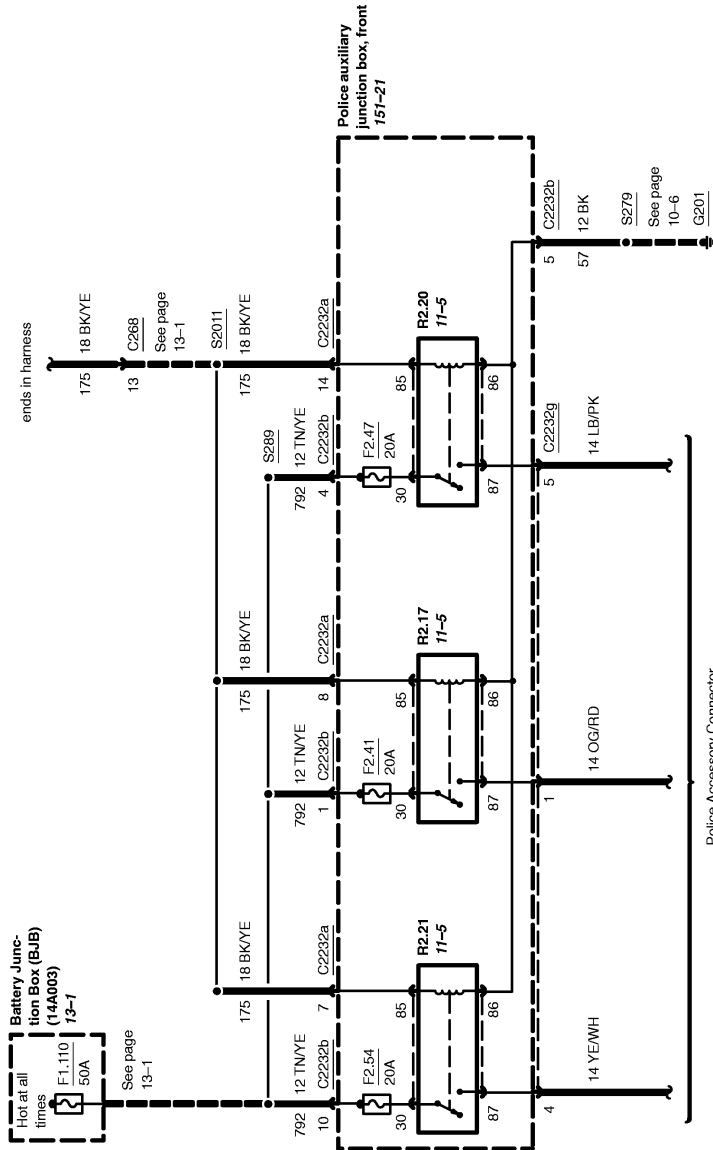

Crown Victoria/Grand Marquis '04

A0091621

# Section 6: Reference Information

## 96-3 Police Option

A0091622

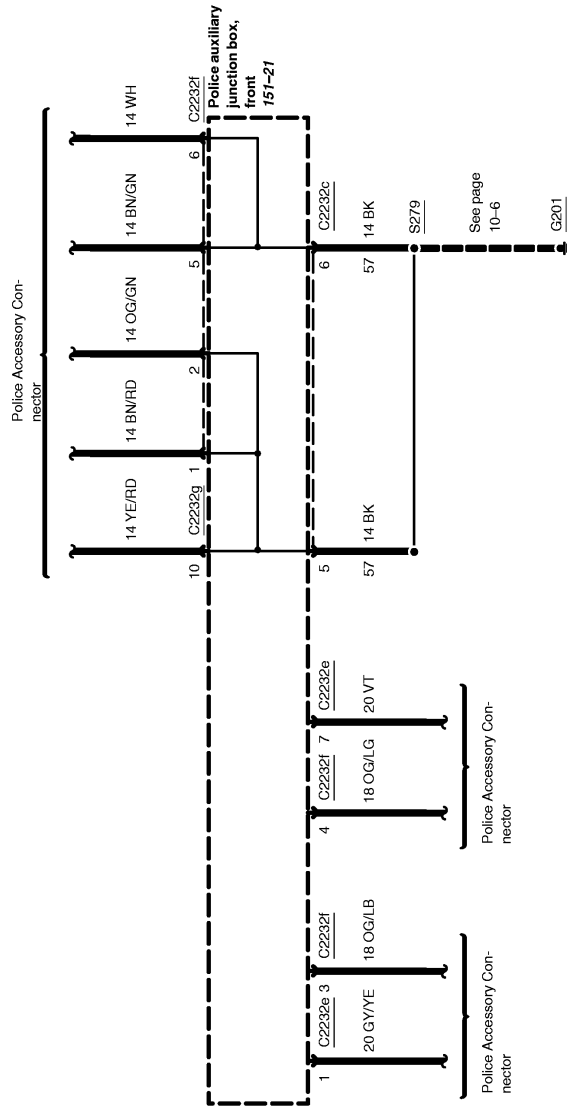

Crown Victoria/Grand Marquis '04

# Section 6: Reference Information

Police Option 96-4

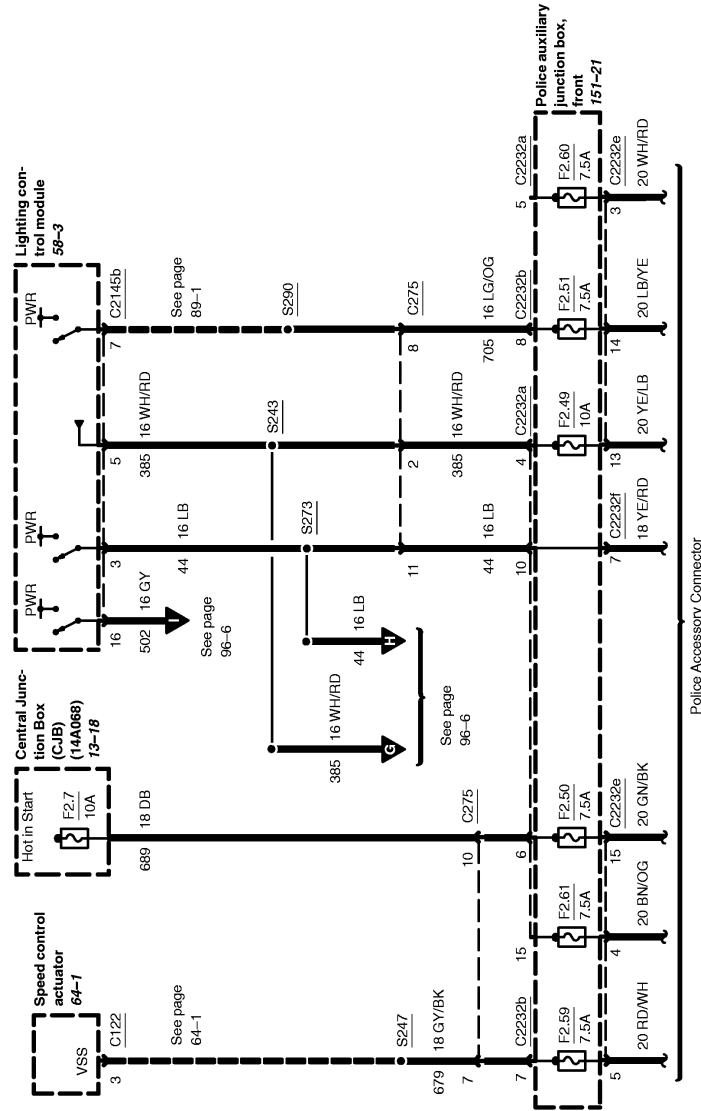

Crown Victoria/Grand Marquis '04

A0092194

## Section 6: Reference Information

### 96-5 Police Option

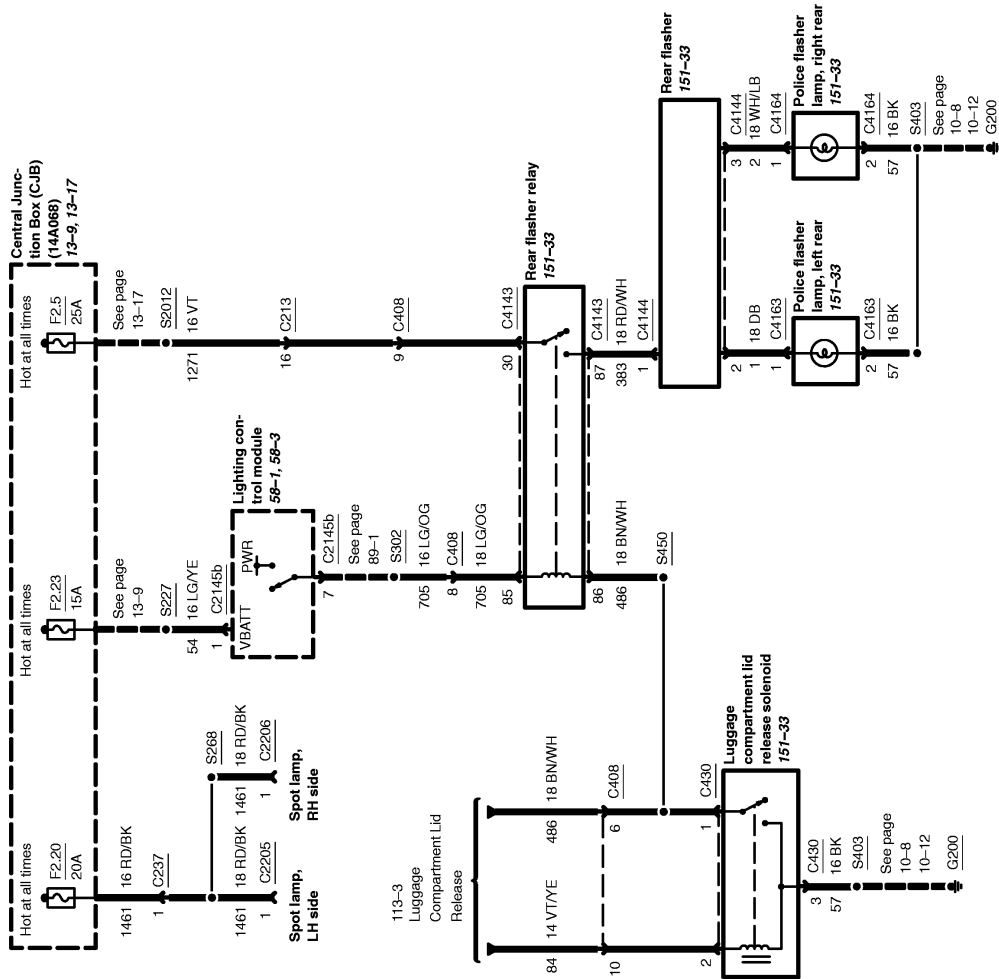

Crown Victoria/Grand Marquis '04

A0092195

# Section 6: Reference Information

Police Option 96-6

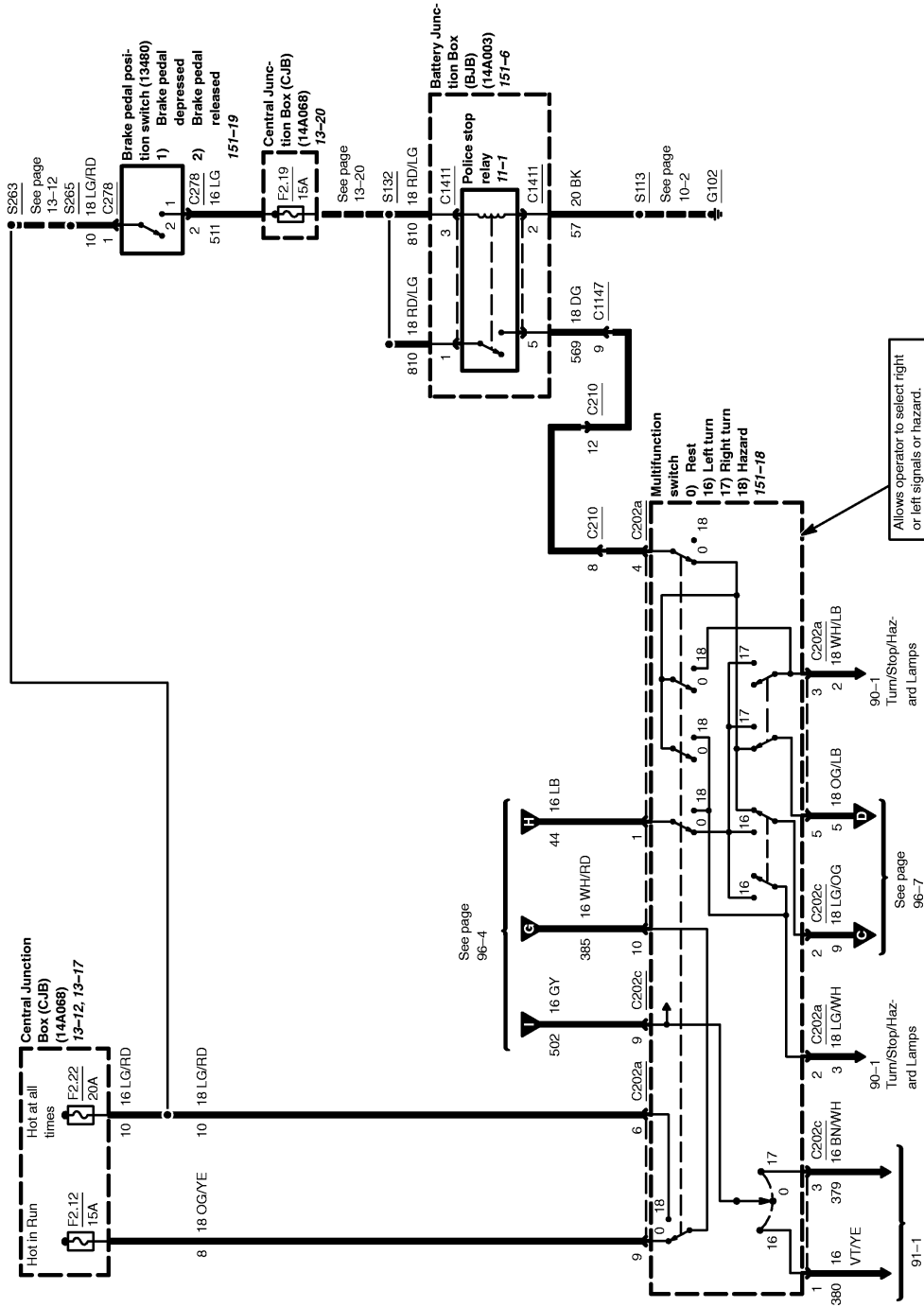

Crown Victoria/Grand Marquis '04

A0092196



# Section 6: Reference Information

96-7 Police Option

A0092197

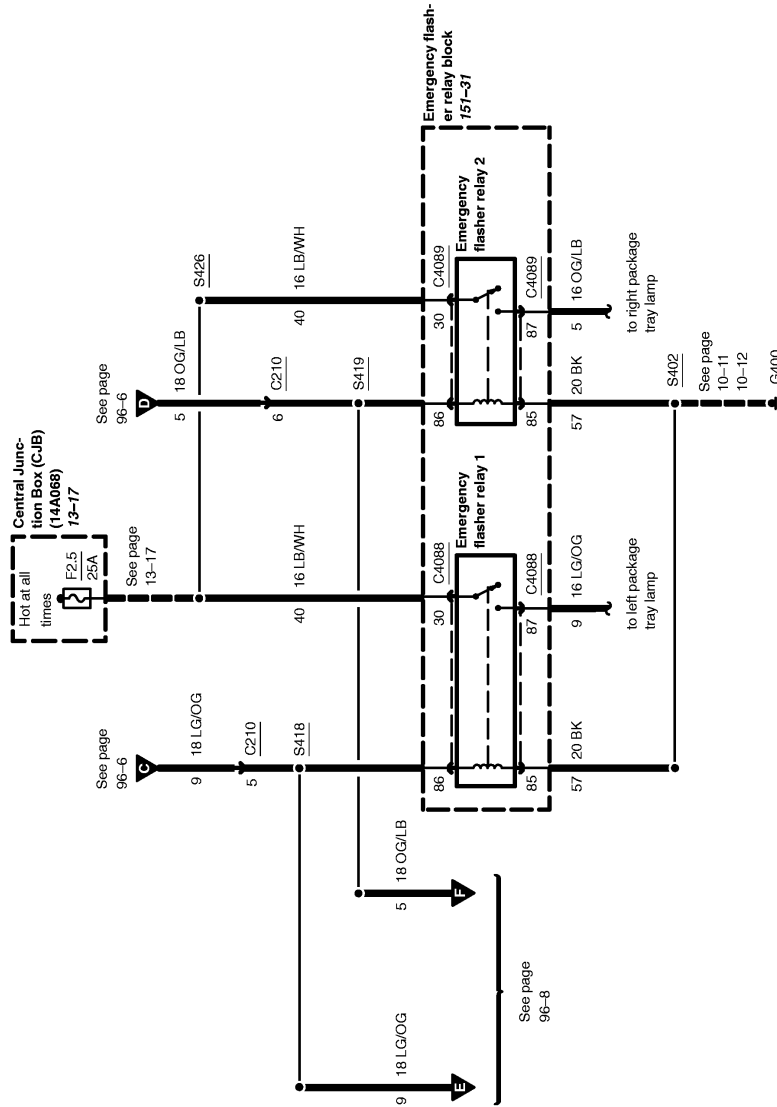

Crown Victoria/Grand Marquis '04

# Section 6: Reference Information

Police Option 96-8

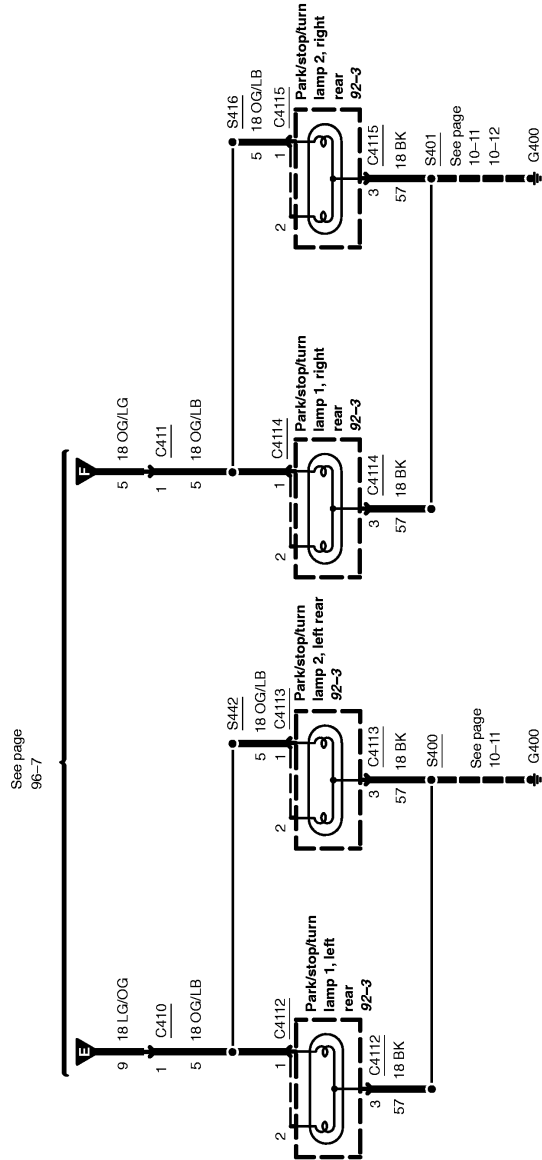

See page 96-7

See page 10-11

A0092198

Crown Victoria/Grand Marquis '04

# Section 6: Reference Information

## 96-9 Police Option

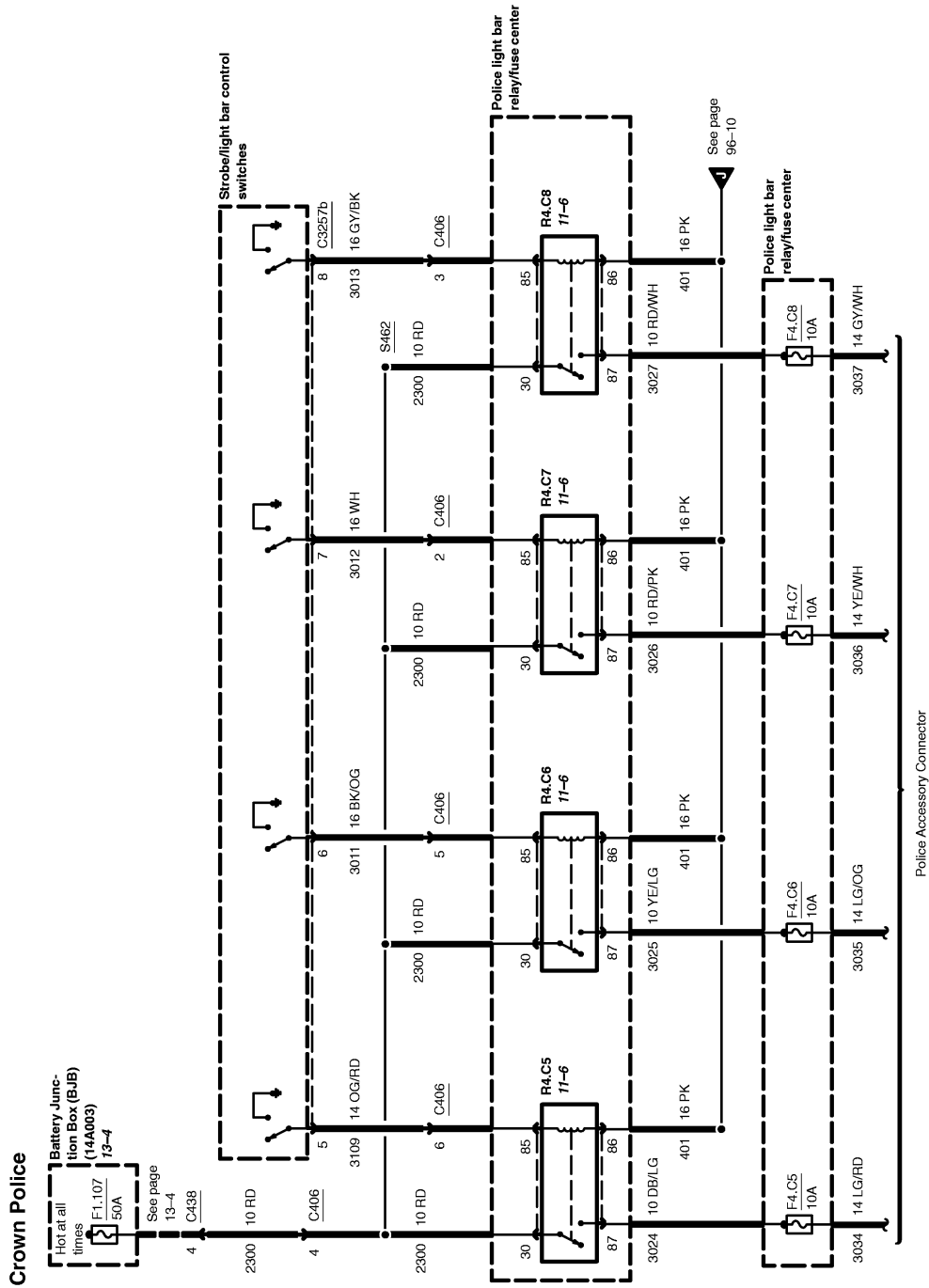

Crown Victoria/Grand Marquis '04

A0092199

# Section 6: Reference Information

Police Option 96-10

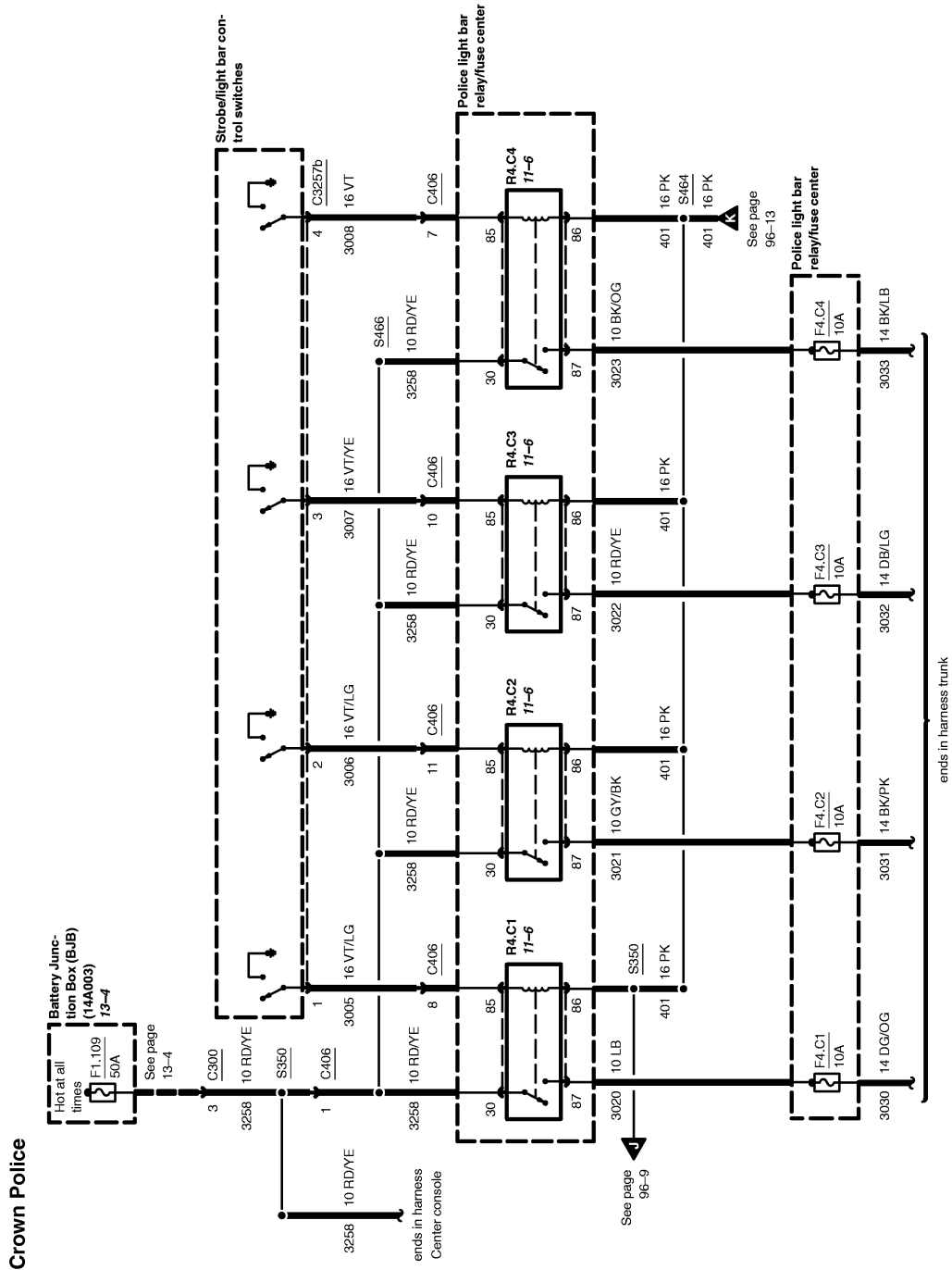

Crown Victoria/Grand Marquis '04

A0092200

## Section 6: Reference Information

### 96-11 Police Option

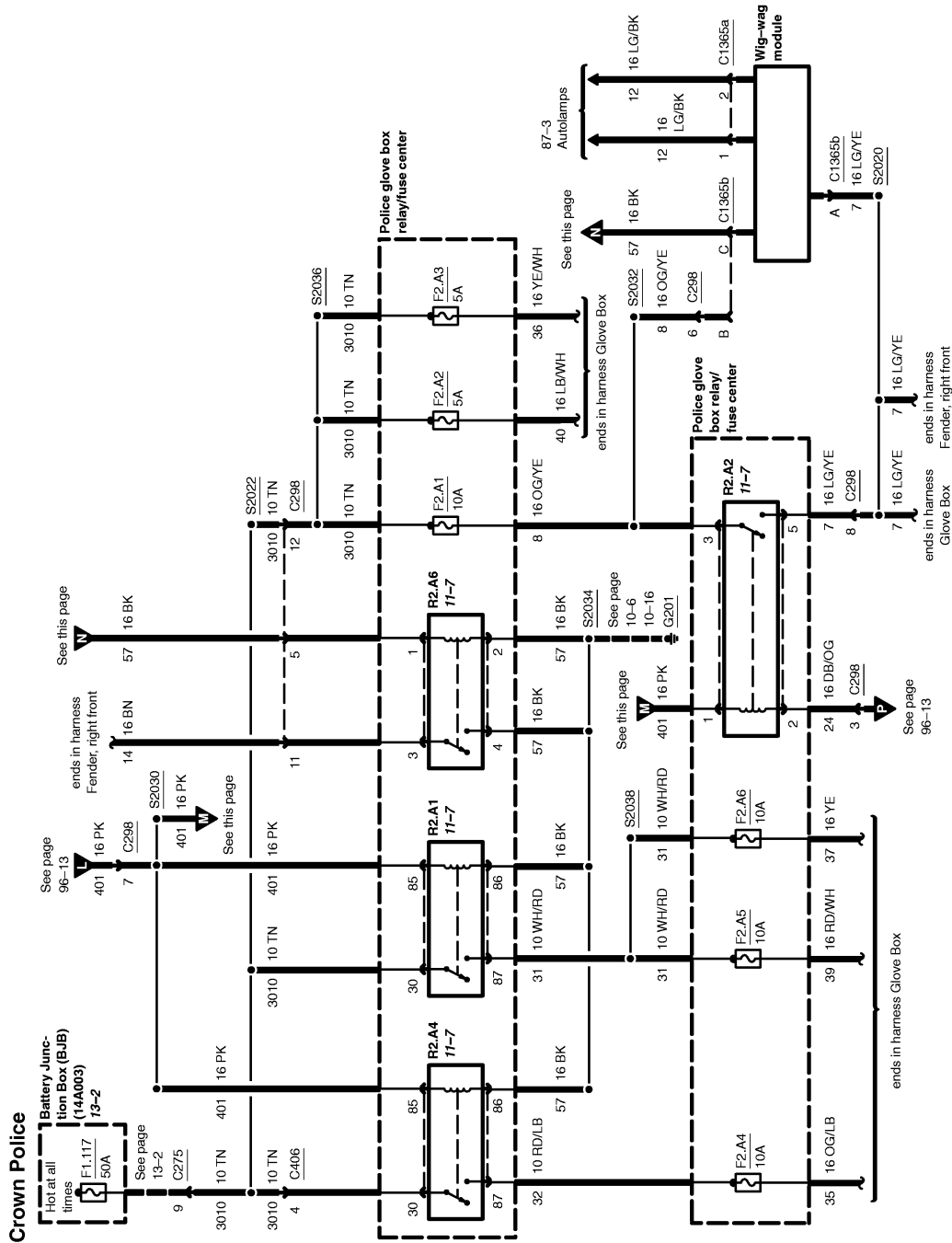

Crown Victoria/Grand Marquis '04

A0092201

# Section 6: Reference Information

Police Option 96-12

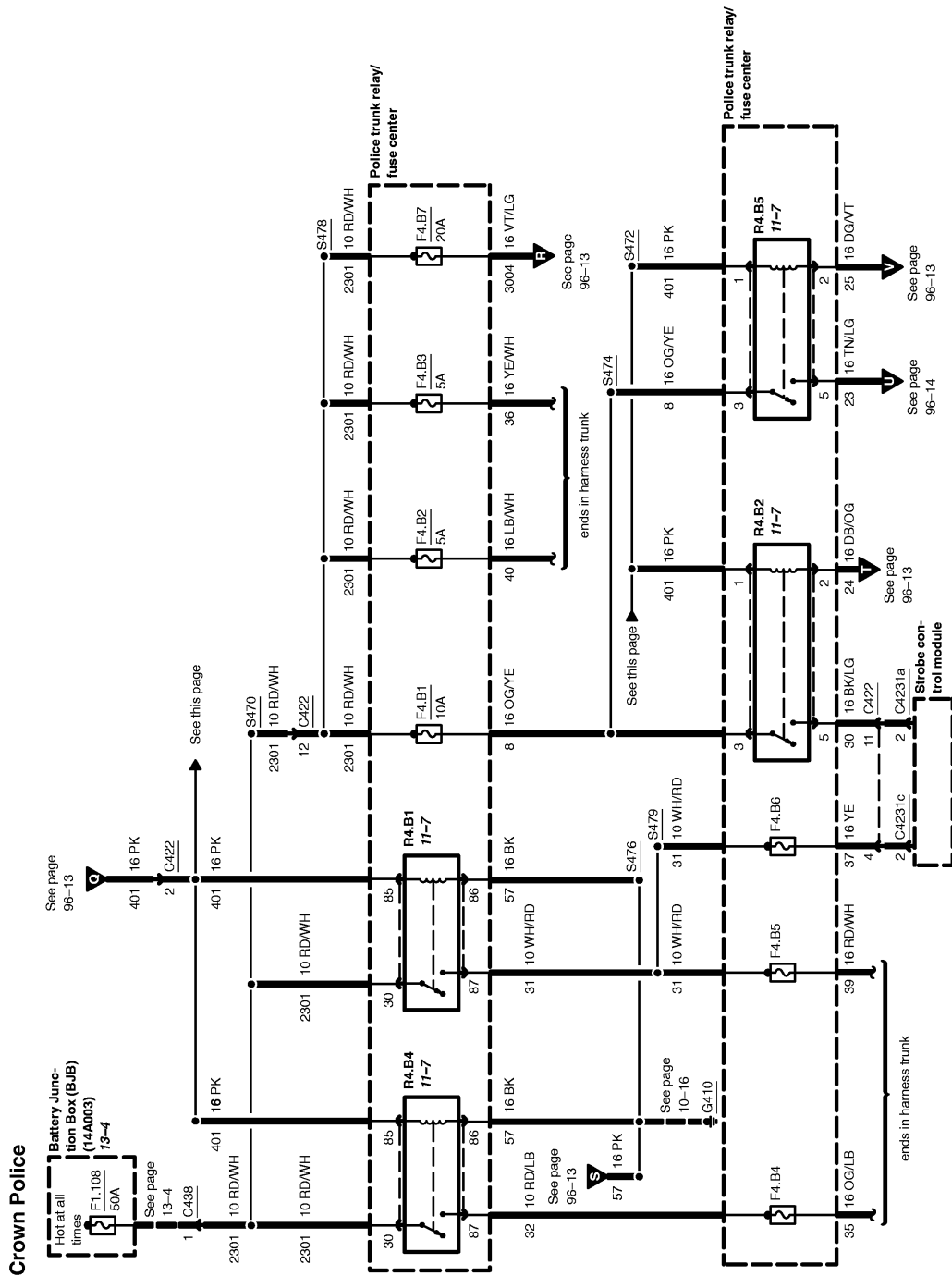

A0092202

Crown Victoria/Grand Marquis '04

## Section 6: Reference Information

### 96-13 Police Option

A0092203



Crown Victoria/Grand Marquis '04

# Section 6: Reference Information

Police Option 96--14

Crown Police

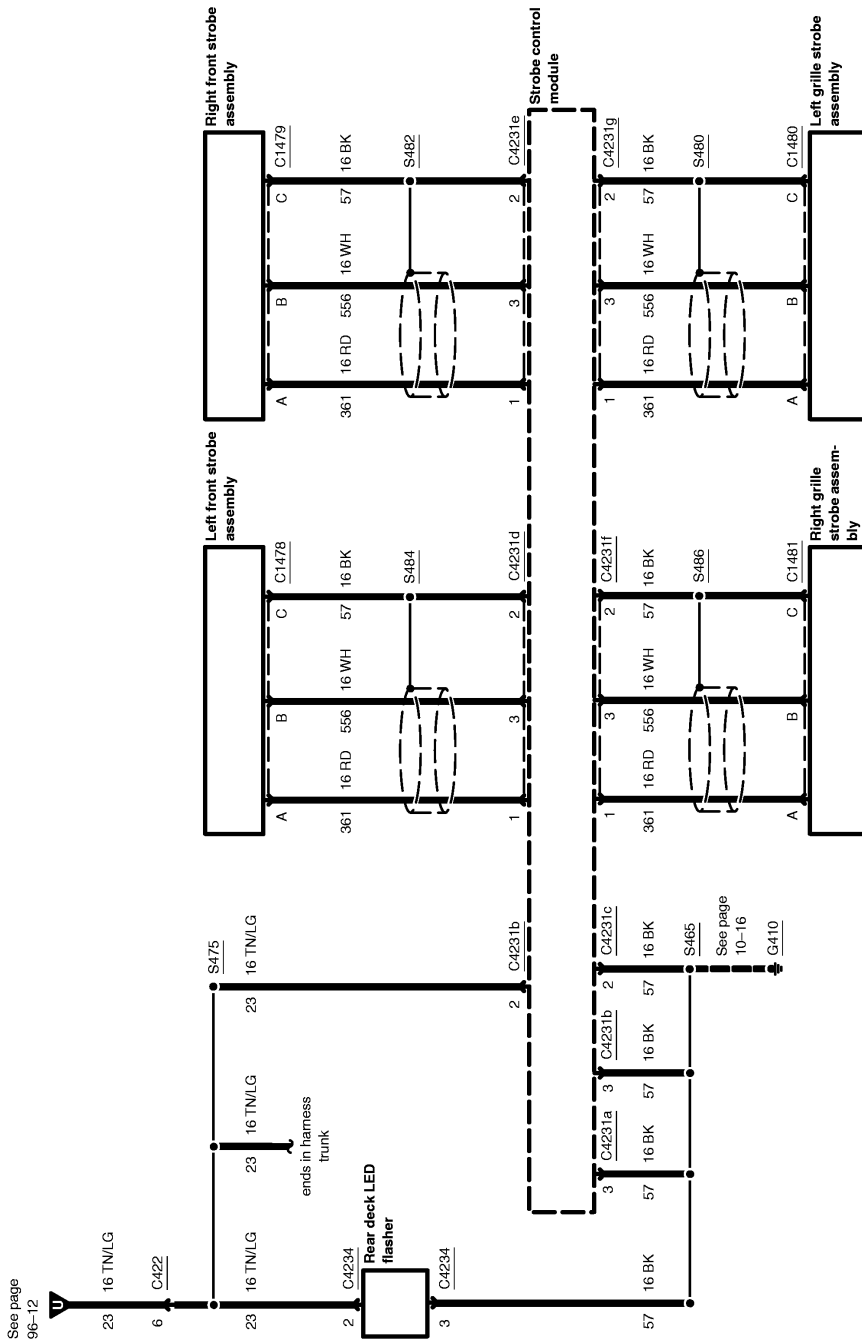

See page 96-12

ends in harness trunk

See page 10-16

Crown Victoria/Grand Marquis '04

A0092204



# Section 6: Reference Information

## 96-15 Police Option

### Crown Police

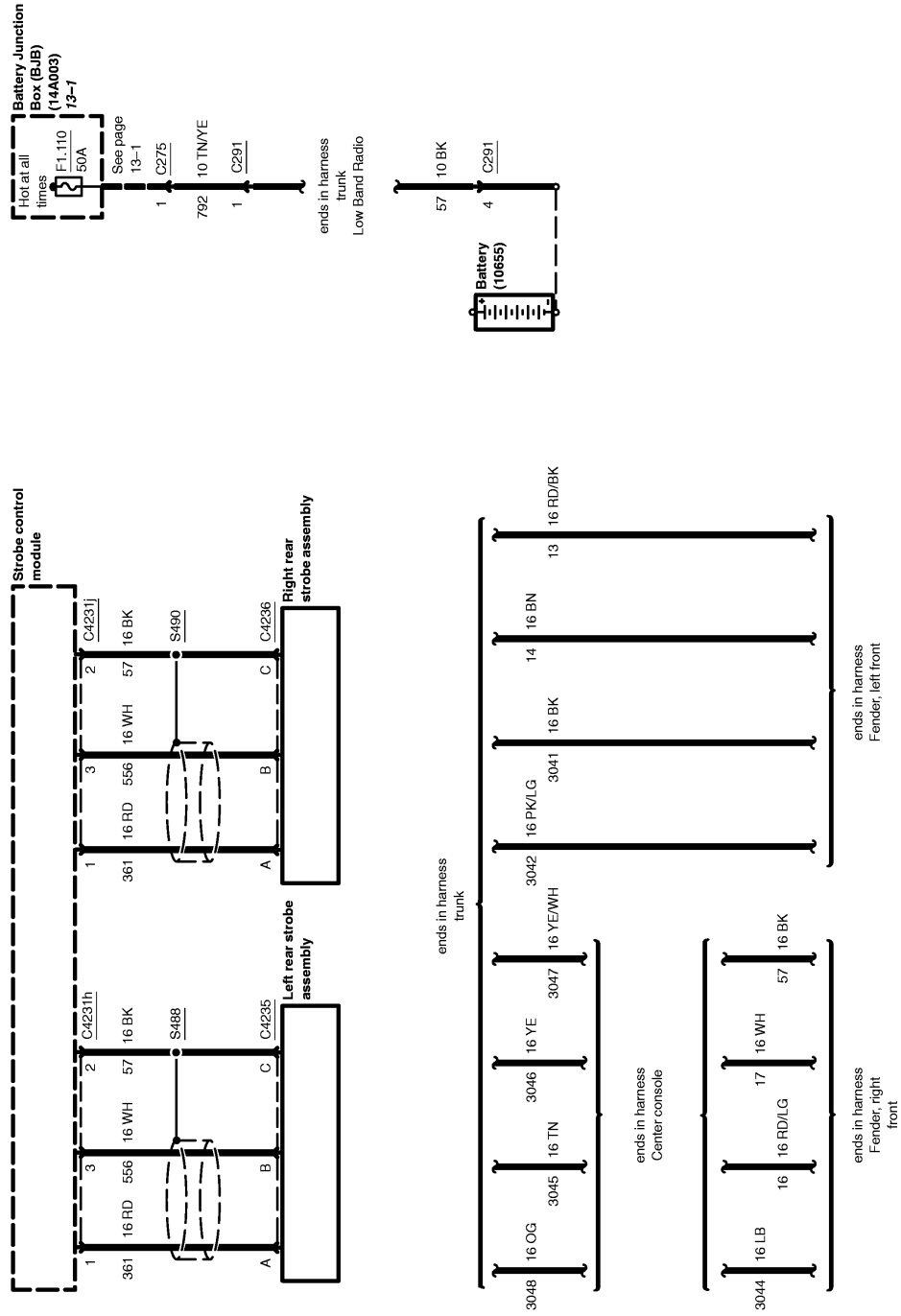

### Crown Victoria/Grand Marquis '04

A0092205

# Section 6: Reference Information

## 130-1 Radio

A0092206

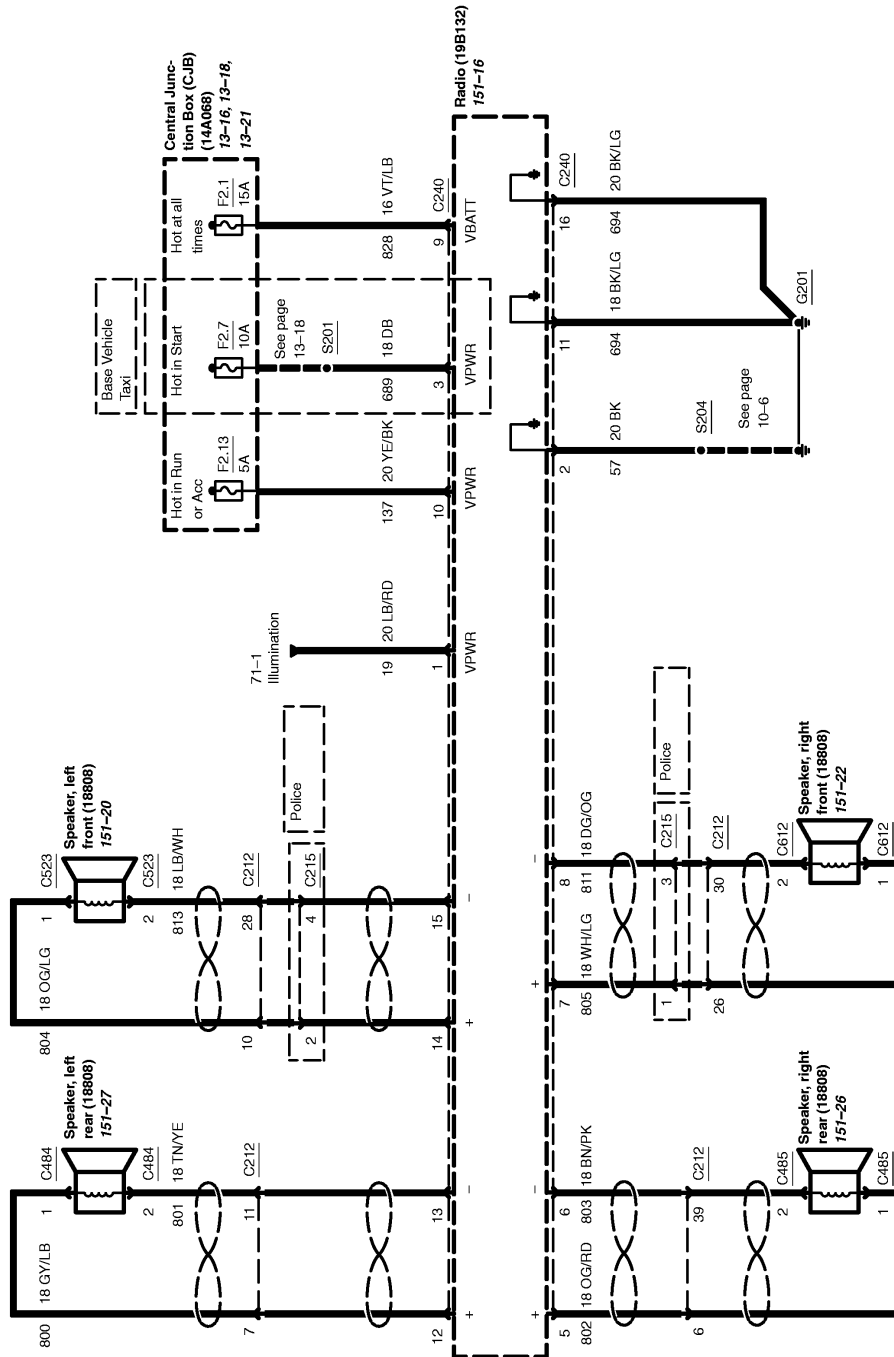

Crown Victoria/Grand Marquis '04